

403F-11

9.8 kW @ 1800 rpm

ElectropaK

400

Series

Basic technical data

Number of cylinders	3
Cylinder arrangement	Vertical inline
Cycle	4 stroke
Induction system	Naturally aspirated
Compression ratio	23:1
Bore	77 mm
Stroke	81 mm
Cubic capacity	1.131 litres
Direction of rotation when viewed from flywheel	Anticlockwise
Firing order	1, 2, 3

Weight of ElectropaK

Dry (estimated)	129.2 kg
-----------------	----------

Overall dimensions of ElectropaK

Height	702 mm
Length	754 mm
Width (including mounting brackets)	437 mm

Moments of inertia (mk²)

Engine rotational components	0.012 kgm ²
Flywheel	1.51 kgm ²

Centre of gravity

Forward from rear of block	98 mm
Above centre line of block	67 mm
Offset to RHS of centre line	2 mm

Ratings

Steady state speed stability at constant load	± 0.75%
---	---------

Performance

- Note:** All data based on operation to ISO 3046/1:2002 standard reference conditions.
- Note:** For engines operating in ambient conditions other than the standard reference conditions stated below, a suitable derate must be applied.
- Note:** Derate tables for increased ambient temperature and/or altitude are available, please contact Perkins Applications Department.

Test conditions

Air temperature	25°C
Barometric pressure	100 kPa
Relative humidity	31.5%
Air inlet restriction at maximum power (nominal)	3 kPa
Exhaust back pressure at maximum power (nominal)	10.2 kPa
Fuel temperature (inlet pump)	40°C
All ratings certified to within	± 5%

Sound level

Average sound pressure level for bare engine (without inlet and exhaust) at 1 metre	78.5 dB(A)
---	------------

- Note:** If the engine is to operate in ambient conditions other than those of the test conditions, suitable adjustments must be made for these changes.

For full details, contact Perkins Technical Service Department.

Emissions Statement: Certified to the requirements of EPA Tier 4 Final under 40 CFR Part 1039.

General installation, 403F-11 ElectropaK @ 1800 rpm

Designation	Units	Type of operation and application	
		Prime power (60 Hz)	Standby power (60 Hz)
Gross engine power	kWb	8.9	9.8
ElectropaK nett engine power	kWm	8.5	9.4
Gross BMEP	kPa	525	578
Engine coolant flow (Water pump ratio 1.285:1)	litres/min	32.5	
Combustion air flow	m ³ /min	0.9	
Exhaust gas flow (maximum)	m ³ /min	2.2	2.4
Exhaust gas temperature outlet (maximum)	°C	437	515
Overall thermal efficiency (nett)	%	32	31
Typical generator sets electrical output (0.8 pf 25°C)	kWe	9.0	9.9
	kVA	11.2	12.4
Assumed alternator efficiency	%	87	

Energy balance

Designation	Units	Type of operation and application	
		Prime power (60 Hz)	Standby power (60 Hz)
Energy in fuel	kWt	27.5	30.2
Energy in power output (gross)	kWb	8.9	9.8
Energy to cooling fan	kWm	0.4	
Energy in power output (nett)	kWm	8.5	9.4
Energy to exhaust	kWt	9.1	10.0
Energy to coolant and oil	kWt	8.2	9.0
Energy to radiation	kWt	1.3	1.4

Cooling system

Radiator

Radiator face area	0.147 m ²
Material and number of rows	Aluminium, 2 rows
Material and matrix density	Aluminium, 14.5 fins/inch
Width of matrix	334 mm
Height of matrix	440 mm
Pressure cap setting	90 kPa
Estimated cooling air flow reserve	0.125 kPa

Fan

Diameter	320 mm
Drive ratio	1.285:1
Number of blades	6
Material	Nylon
Type	Pusher

Total coolant capacity

ElectropaK (with radiator)	5.2 litres
ElectropaK (without radiator)	1.9 litres
Maximum top tank temperature	112°C
Thermostat operation range	75-87°C

Note: Recommended coolant: 50% anti freeze/50% water.

For complete details of recommended coolant specifications, refer to the Operation and Maintenance manual for this engine model.

Duct allowance

Maximum additional restriction to cooling airflow and resultant minimum airflow		
Ambient clearance 50% Glycol	Duct allowance (Pa)	m ³ /sec
53°C	0	0.67
46°C	60	0.58

Electrical system

Alternator	15 amps, 12 volts
Starter motor	Bosch 1.1 kW, 12 volts
Number of teeth on flywheel	96
Number of teeth on starter pinion	9

Exhaust system

Maximum back pressure	10.2 kPa
-----------------------	----------

Exhaust outlet size

Horizontal	34 mm
Vertical	40 mm

Engine mounting

Maximum static bending moment at rear face of block	500 Nm
---	--------

Fuel system

Type of injection	Indirect Injection
Fuel injection pump	Cassette type
Fuel injector	Pintle nozzle
Nozzle opening pressure	11.8 MPa
Maximum particle size	25 Microns

Fuel lift pump

Fuel lift pump type	Mechanical (camshaft driven)
Flow/hour	63 litres/hour
Pressure	10 kPa
Maximum suction head	0.8 m
Maximum static pressure head	3.0 m
Maximum fuel temperature at lift pump inlet	65°C
Maximum fuel filter service interval:	
Standard service option	500 hours
Extended service option (ULSD fuel/up to 70% load factor)	1000 hours
Governor type	Mechanical
Speed control conforms to	G2

Fuel specification

USA Fed Off Highway	EPA Part 1065.703 ULSD
Europe Off Highway	EU 2004/26/EC Stage 3B/4

Note: For further information on fuel specifications and restrictions, refer to the Operation and Maintenance manual fuels section for this engine model.

Fuel consumption

Fuel consumption for 403F-11 @ 1800 rpm				
Power rating	110%	100%	75%	50%
g/kWh	252	255	267	308
Litres/hour	3.1	2.8	2.2	1.7

Cold start recommendations

Minimum cranking speed @ 1800 rpm

Minimum starting temperature	Grade of engine lubricating oil	Battery specifications			
		BS3911 Cold start amps	SAEJ537 Cold cranking amps	Number of batteries required	Commercial reference number
0°C	20W	340	540	1	069
-15°C	10W	340	540	1	069
-20°C	5W	420	590	1	072

Induction system

Maximum air intake restriction

Clean filter..	3.0 kPa
Dirty filter..	6.4 kPa
Air filter type..	Dry element type

Lubrication system

Lubricating oil capacity

Maximum sump capacity:	
Standard service option	4.4 litres
Extended service option	4.9 litres
Minimum sump capacity:	
Standard service option	3.4 litres
Extended service option	3.9 litres
Maximum oil temperature (continuous operation).....	125°C
Maximum oil temperature (intermittent operation).....	135°C

Maximum engine operating angles

Front up, front down, right side or left side	Continuous
Standard service option	35°
Extended service option	10°

Lubricating oil pressure

Minimum oil pressure.....	150 kPa
Relief valve opens	402 kPa
At maximum no-load speed	216-400 kPa
Oil flow at rated speed.....	7.9 litres/min
Maximum oil/oil filter service interval	
Standard service option	500 hours
Extended service option.....	1000 hours
(ULSD fuel/up to 70% load factor)	

Recommended SAE viscosity

A single or multigrade oil conforming to API-CH-4 or ACEA E5 must be used.

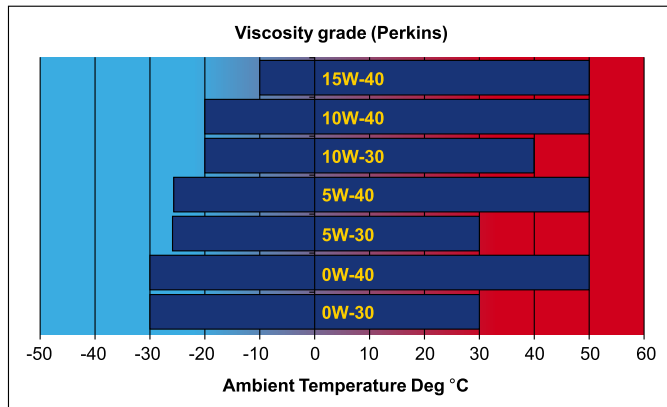

Engine mounting

Maximum static bending moment at rear face of block... 500 Nm

Load acceptance

The figures below comply with the requirements of classification 3 and 4 of ISO 8528-12 and G2 operating limits stated in ISO 8528-5.

Initial load application: When engine reaches rated speed (15 seconds maximum after engine starts to crank)		
Descriptor	Units	60 Hz
Prime power	%	TBA
Load	kWm (kWe)	TBA
Transient frequency deviation	%	TBA
Frequency recovery	Seconds	TBA

The figures shown in the table above were obtained under the following test conditions:

Ambient temperature	TBA °C
Governing mode	TBA %
Alternator inertia	kgm ²

Note: All tests were conducted using an engine installed and serviced to Perkins Engines Company Limited recommendations.

Note: The general arrangement drawings shown in this data sheet are for guidance only. The latest versions should be requested from the Perkins Applications Department.

403F-11 ElectropaK - Left side view (extended service interval option shown)

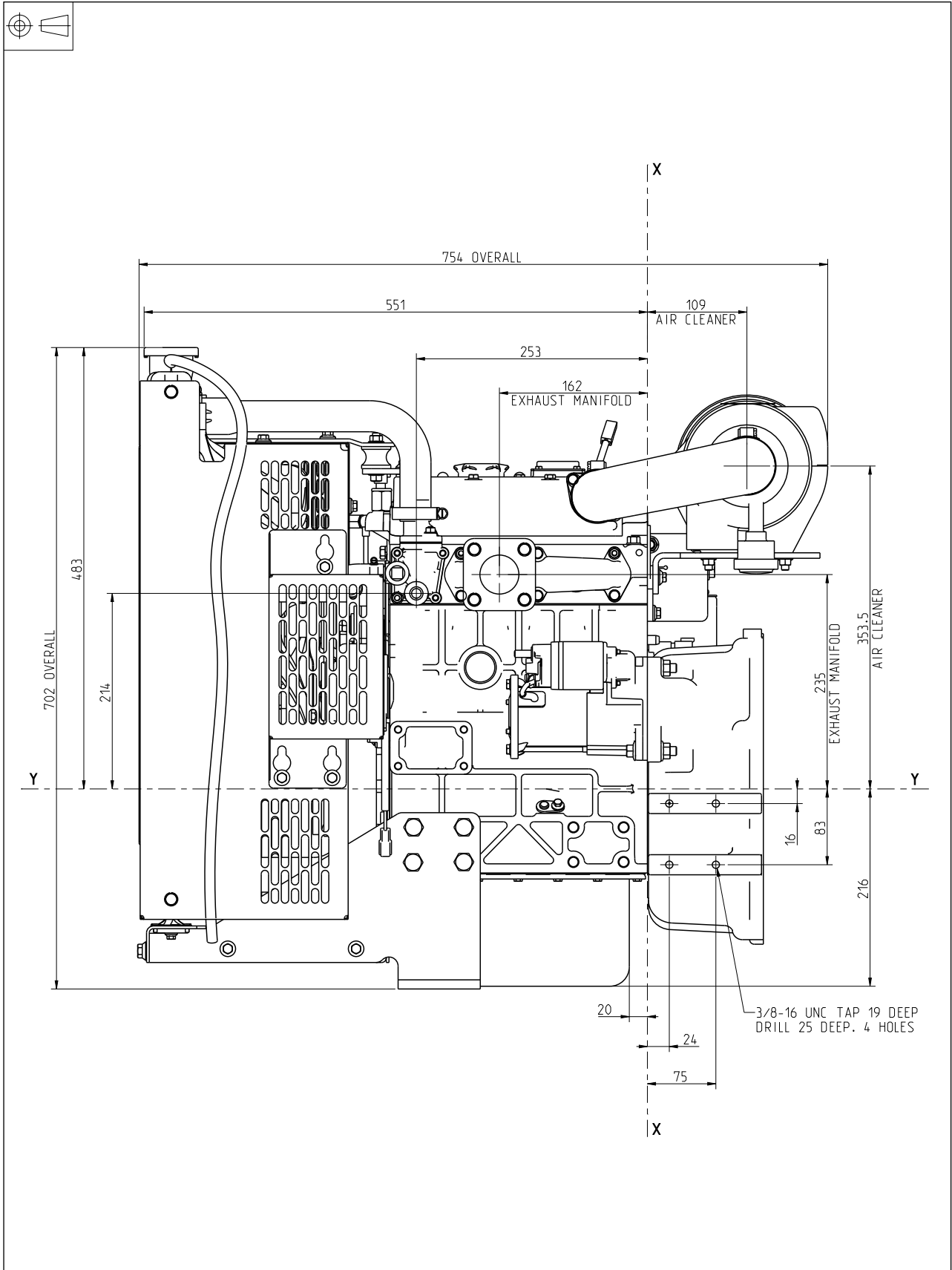

403F-11 ElectropaK - Front view (extended service interval option shown)

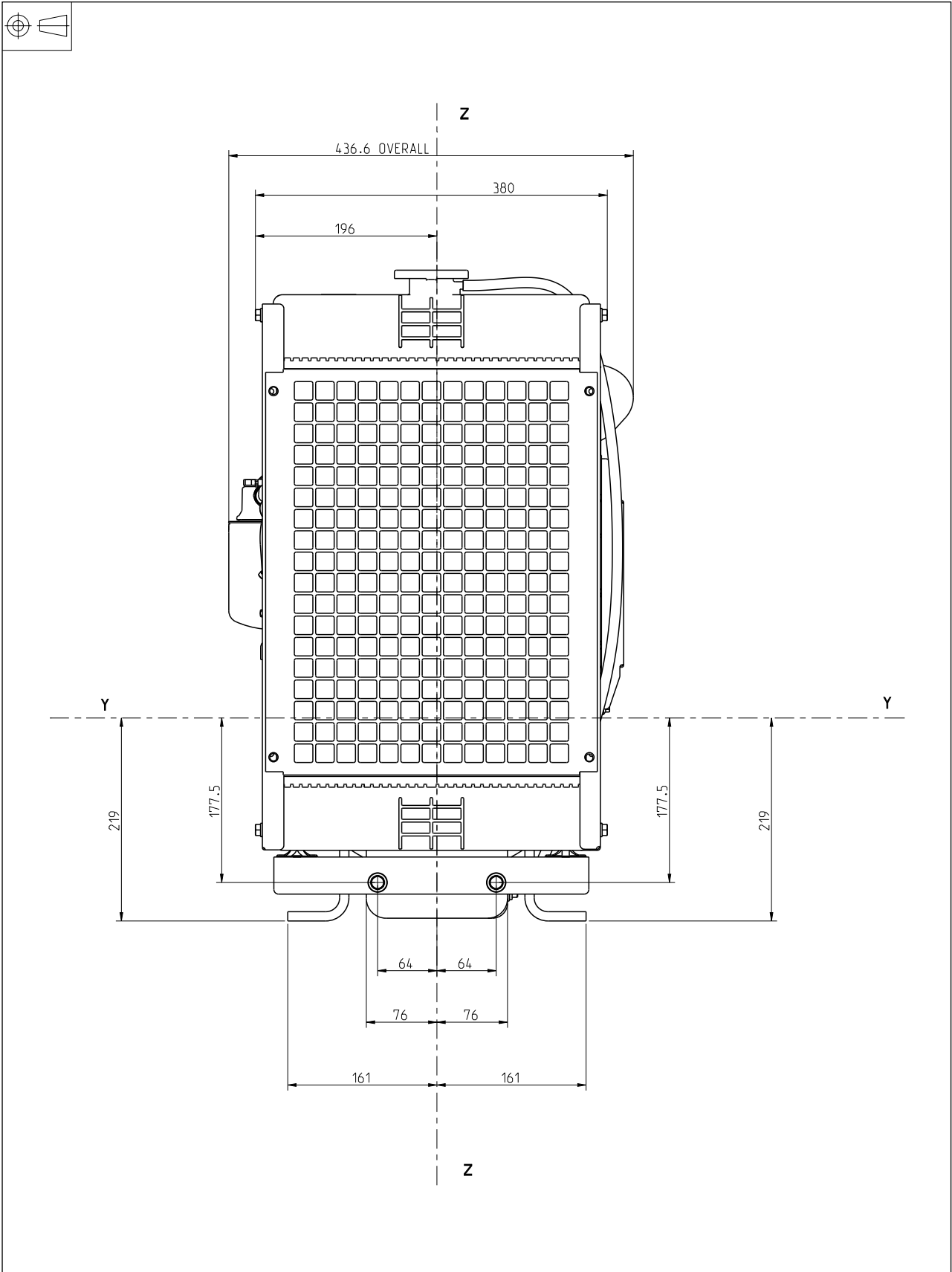

403F-11 ElectropaK - Right side view (extended service interval option shown)

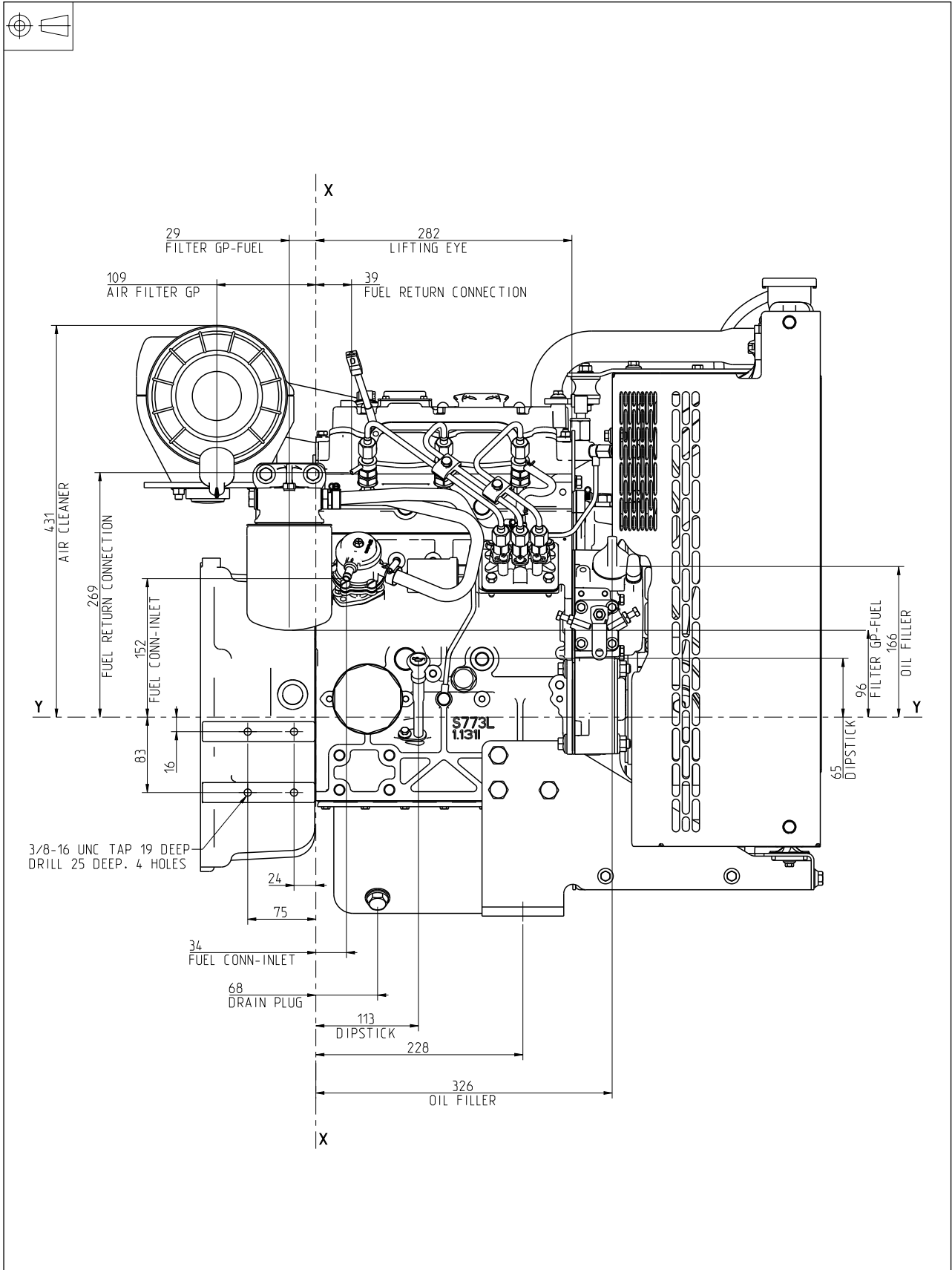

403F-11 ElectropaK - Rear view (extended service interval option shown)

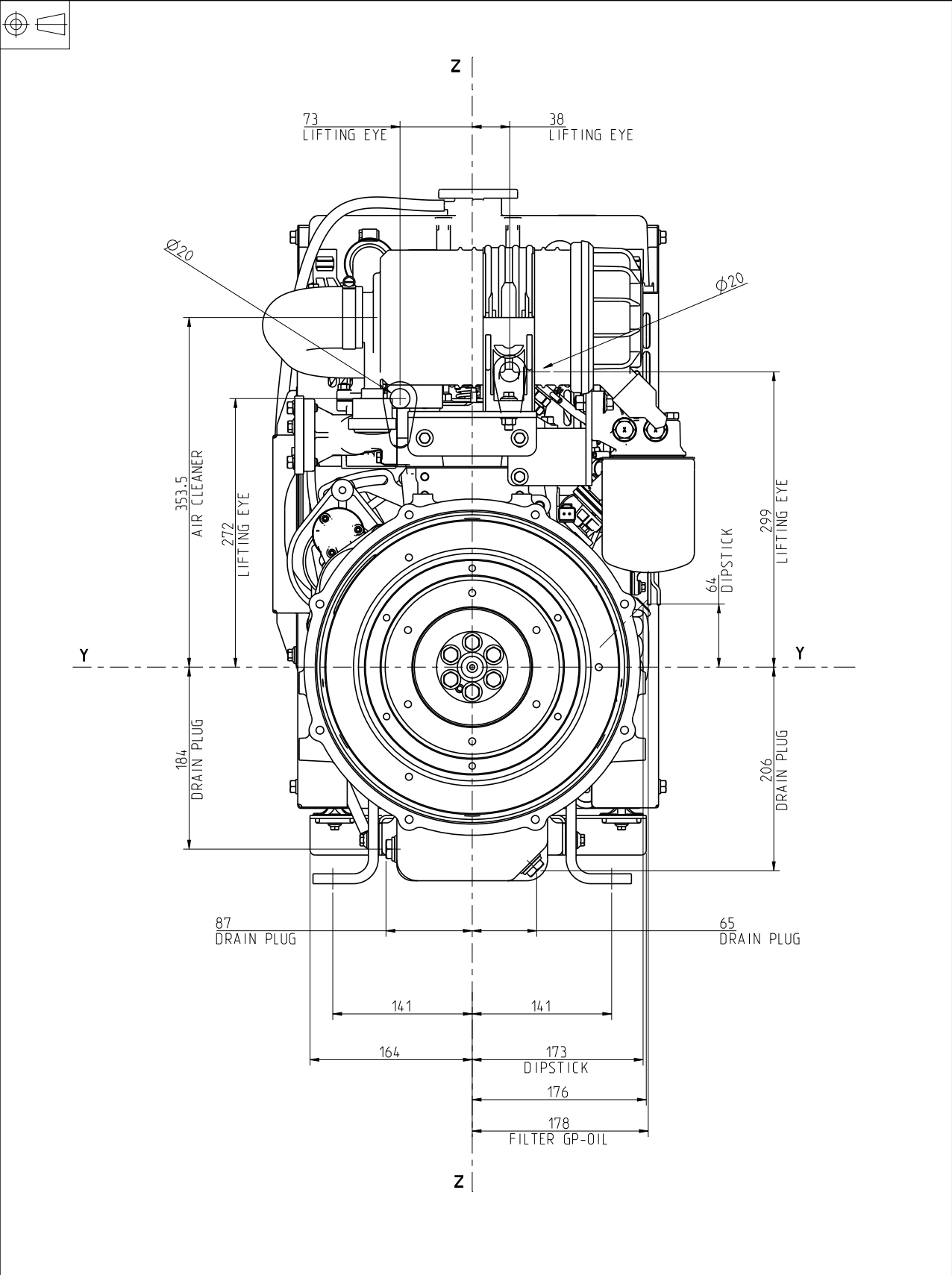

403F-11 ElectropaK - Plan view (extended service interval option shown)

