

# Systems Operation Testing and Adjusting

---

## **402J-05, 403J-07, 403J-11, 403J-11T, 403J-15, 403J-17 and 403J-17T Industrial Engines**

---

IH (Engine)  
IF (Engine)  
IG (Engine)  
IZ (Engine)  
IS (Engine)  
IK (Engine)  
IJ (Engine)

## Important Safety Information

Most accidents that involve product operation, maintenance and repair are caused by failure to observe basic safety rules or precautions. An accident can often be avoided by recognizing potentially hazardous situations before an accident occurs. A person must be alert to potential hazards. This person should also have the necessary training, skills and tools to perform these functions correctly.

**Incorrect operation, lubrication, maintenance or repair of this product can be dangerous and could result in injury or death.**

**Do not operate or perform any lubrication, maintenance or repair on this product, until you have read and understood the operation, lubrication, maintenance and repair information.**

Safety precautions and warnings are provided in this manual and on the product. If these hazard warnings are not heeded, bodily injury or death could occur to you or to other persons.

The hazards are identified by the "Safety Alert Symbol" and followed by a "Signal Word" such as "DANGER", "WARNING" or "CAUTION". The Safety Alert "WARNING" label is shown below.



The meaning of this safety alert symbol is as follows:

**Attention! Become Alert! Your Safety is Involved.**

The message that appears under the warning explains the hazard and can be either written or pictorially presented.

Operations that may cause product damage are identified by "NOTICE" labels on the product and in this publication.

**Perkins cannot anticipate every possible circumstance that might involve a potential hazard. The warnings in this publication and on the product are, therefore, not all inclusive. You must not use this product in any manner different from that considered by this manual without first satisfying yourself that you have considered all safety rules and precautions applicable to the operation of the product in the location of use, including site-specific rules and precautions applicable to the worksite. If a tool, procedure, work method or operating technique that is not specifically recommended by Perkins is used, you must satisfy yourself that it is safe for you and for others. You should also ensure that you are authorized to perform this work, and that the product will not be damaged or become unsafe by the operation, lubrication, maintenance or repair procedures that you intend to use.**

The information, specifications, and illustrations in this publication are on the basis of information that was available at the time that the publication was written. The specifications, torques, pressures, measurements, adjustments, illustrations, and other items can change at any time. These changes can affect the service that is given to the product. Obtain the complete and most current information before you start any job. Perkins dealers or Perkins distributors have the most current information available.



**When replacement parts are required for this product Perkins recommends using Perkins replacement parts.**

**Failure to heed this warning can lead to premature failures, product damage, personal injury or death.**

---

**In the United States, the maintenance, replacement, or repair of the emission control devices and systems may be performed by any repair establishment or individual of the owner's choosing.**

## Table of Contents

### Systems Operation Section

General Information .....	4
Fuel System .....	15
Air Inlet and Exhaust System .....	20
Lubrication System .....	22
Cooling System .....	23
Basic Engine.....	24
Electrical System .....	26

### Testing and Adjusting Section

#### Fuel System

Fuel System - Inspect.....	36
Air in Fuel - Test .....	36
Finding Top Center Position for No. 1 Piston .....	37
Fuel Injection Timing - Check .....	37
Fuel Injector - Test.....	38
Fuel Quality - Test .....	41
Fuel System - Prime .....	42
Gear Group (Front) - Time .....	47
Governor - Adjust.....	47

#### Air Inlet and Exhaust System

Air Inlet and Exhaust System - Inspect.....	55
Wastegate - Test (Turbocharger - Inspect).....	55
Compression - Test .....	57
Engine Valve Lash - Inspect/Adjust.....	58
Valve Depth - Inspect.....	60
Valve Guide - Inspect.....	60

#### Lubrication System

Engine Oil Pressure - Test .....	62
Engine Oil Pump - Inspect.....	62
Excessive Bearing Wear - Inspect .....	63
Excessive Engine Oil Consumption - Inspect.....	64

#### Cooling System

Cooling System - Check (Overheating) .....	65
Cooling System - Inspect .....	66
Cooling System - Test.....	66
Water Temperature Regulator - Test .....	68
Water Pump - Inspect.....	69

#### Basic Engine

Piston Ring Groove - Inspect.....	71
Connecting Rod - Inspect.....	71
Connecting Rod Bearings - Inspect.....	72
Main Bearings - Inspect .....	72
Cylinder Block - Inspect .....	73
Cylinder Head - Inspect .....	73
Piston Height - Inspect.....	74
Flywheel - Inspect .....	75
Flywheel Housing - Inspect .....	76
Gear Group - Inspect.....	78

#### Electrical System

Alternator - Test.....	79
Battery - Test .....	80

Charging System - Test .....	80
Coolant Temperature Switch - Test (Coolant Temperature Sensor).....	80
Electric Starting System - Test.....	81
Engine Oil Pressure Switch - Test.....	81
Fuel Shutoff Solenoid - Test .....	82
Glow Plugs - Test .....	83

### Index Section

Index.....	85
------------	----

# Systems Operation Section

i08146449

## General Information

### Engine Description

**Note:** When you are ordering new parts, refer to the engine identification number to receive the correct parts. Refer to the Operation and Maintenance Manual, "Product Identification Information" for the correct numbers for your engine.

The 402J-05, 403J-07, 403J-11, 403J-11T, 403J-15, 403J-17, and 403J-17T engines are diesel engines that are controlled with a mechanically actuated fuel injection pump. The engine cylinders are arranged in-line.

The cylinder head assembly has one inlet valve and one exhaust valve for each cylinder. Each cylinder valve has a single valve spring. The pistons have two compression rings and an oil control ring.

It is important to ensure the correct piston height so that the piston does not contact the cylinder head. The correct piston height also ensures the efficient combustion of fuel which is necessary to conform to requirements for emissions.

The crankshaft for the 402J-05 engine has two main bearing journals. The crankshaft for the 403J-07, 403J-11, 403J-11T, 403J-15, 403J-17, and 403J-17T engines have four main bearing journals. End play for all the engines is controlled by the thrust washers that are on the rear main bearing.

The 402J-05, 403J-07, and 403J-11 engines have aluminum bearing caps on the rear main bearing that act as thrust washers.

The timing gears are stamped with timing marks to ensure the correct alignment of the gears during assembly. When the No. 1 piston is at top center compression stroke, the teeth that are stamped on the crankshaft gear and the camshaft gear will be in alignment with the idler gear.

The crankshaft gear turns the idler gear which then turns the camshaft gear.

The fuel injection pump and the fuel priming pump are mounted on the cylinder block. Both pumps are operated by the camshaft lobes.

The fuel injection pump conforms to requirements for emissions. Adjustments to the fuel injection pump timing and high idle should only be made by trained personnel. The fuel injection pumps have mechanical governors that control the engine rpm.

The engine oil pump is a gerotor type pump. The engine oil pump is located in the center of the idler gear. The engine oil pump sends lubricating oil to the main oil gallery through an oil relief valve that is on the right side of the cylinder block. The rocker arm levers receive pressurized oil through an externally located oil line. The oil line runs from the main oil gallery to the cylinder head.

Coolant from the bottom of the radiator passes through the belt driven centrifugal water pump. The coolant is cooled by the radiator and the temperature is regulated by a water temperature regulator.

### Engine Model Views

Due to individual applications, your engine may appear different from the illustrations.

---

**402J-05 Engine**

---

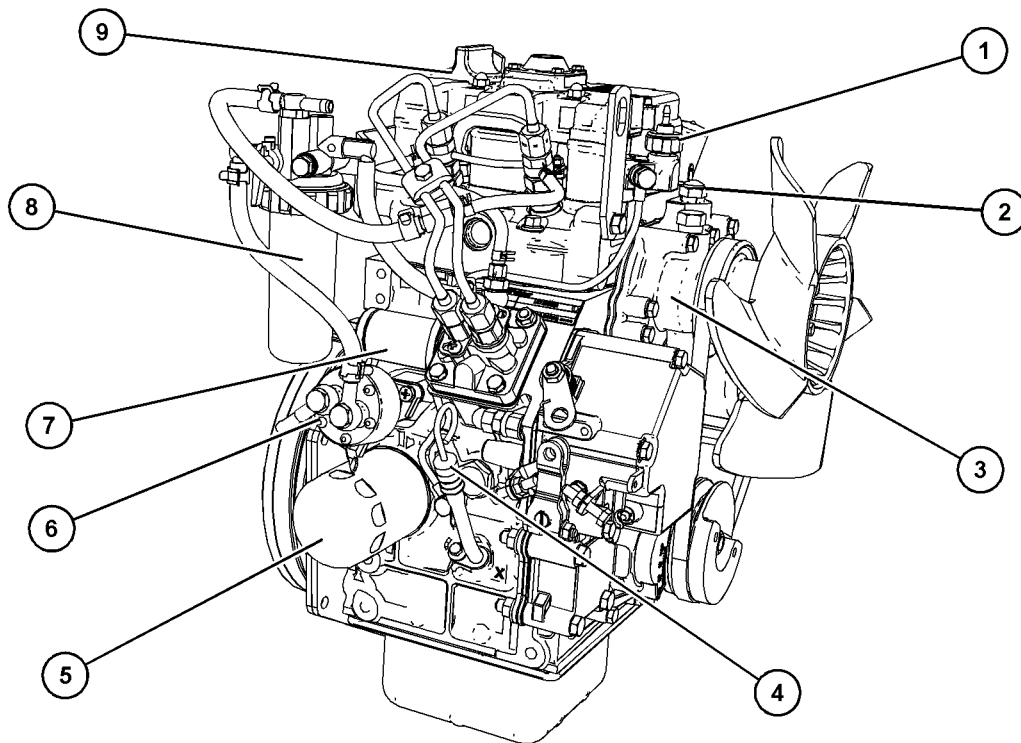

Illustration 1

g06555597

**Typical example**

- (1) Oil pressure switch
- (2) Coolant temperature sensor
- (3) Water pump

- (4) Oil gauge (Dipstick)
- (5) Oil filter
- (6) Fuel transfer pump

- (7) Fuel shutoff solenoid
- (8) Secondary fuel filter
- (9) Oil filler cap

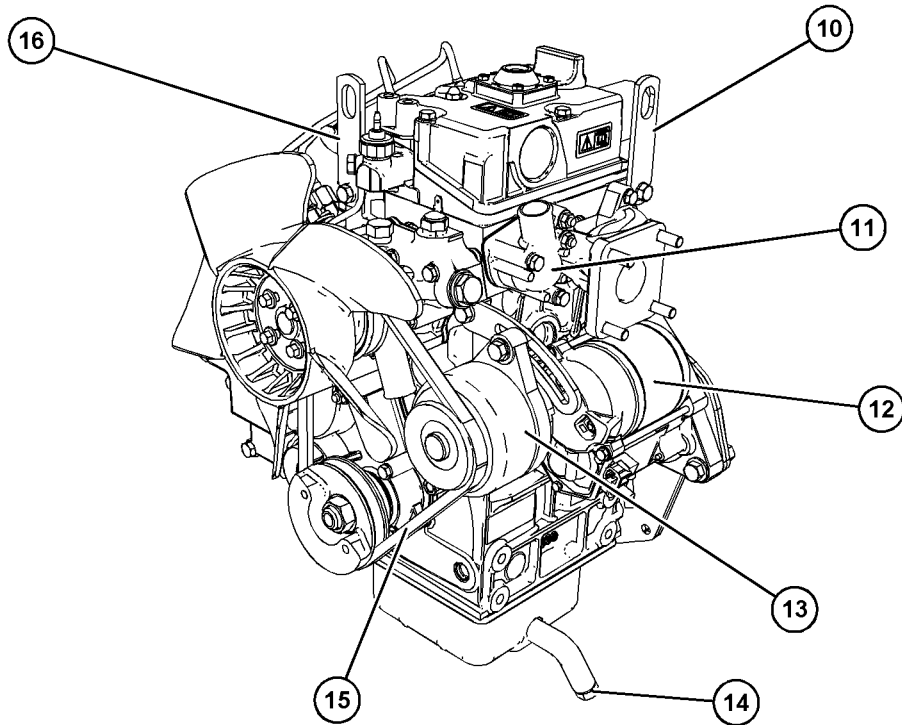

Illustration 2

g06555606

Typical example

- (10) Rear lifting eye
- (11) Water temperature regulator
- (12) Starting motor

- (13) Alternator
- (14) Oil drain plug
- (15) Fan belt

- (16) Front lifting eye

## 403J-11T Engine

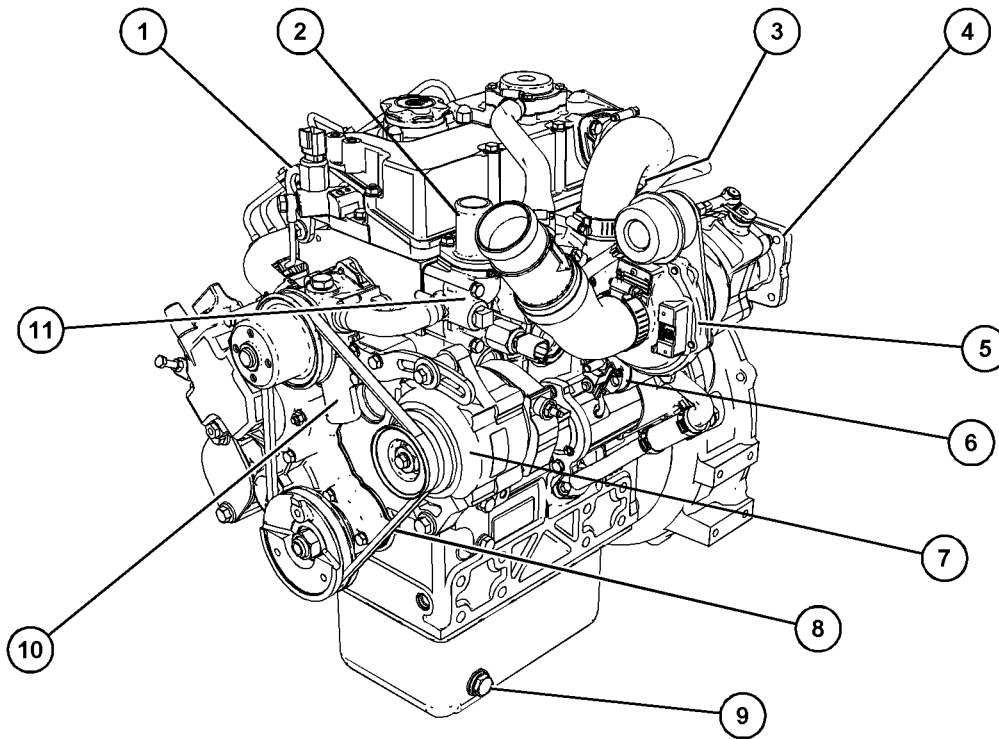

Illustration 3

g06568781

### Typical example

- |                       |                             |  |
|-----------------------|-----------------------------|--|
| (1) Front lifting eye | (5) Turbocharger            | (9) Oil drain plug                       |
| (2) Coolant outlet    | (6) Electric starting motor | (10) Coolant intake                      |
| (3) Rear lifting eye  | (7) Alternator              | (11) Water temperature regulator housing |
| (4) Exhaust elbow     | (8) Drive belt              |  |

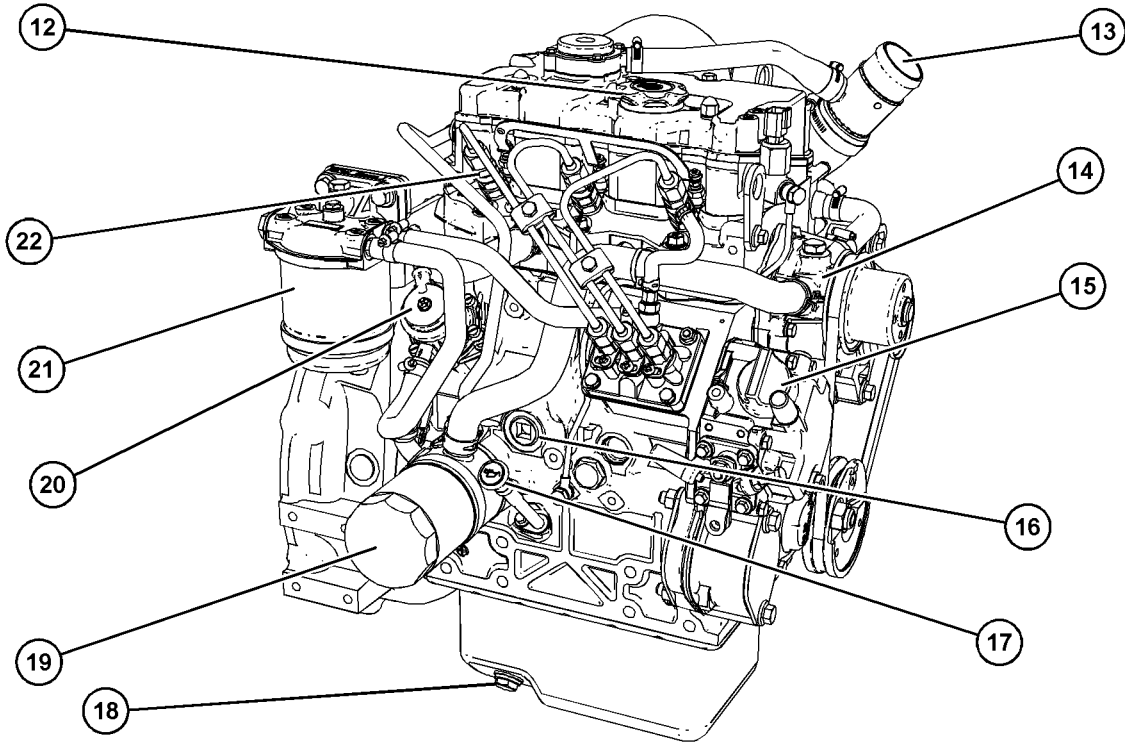

Illustration 4

g06568788

Typical example

- (12) Top oil filler
- (13) Air intake
- (14) Water pump
- (15) Oil filler (lower)

- (16) Cooling drain plug
- (17) Oil gauge (Dipstick)
- (18) Oil drain plug
- (19) Oil filter

- (20) Fuel transfer pump
- (21) Secondary fuel filter
- (22) Fuel injector

### 403J-15 Engine

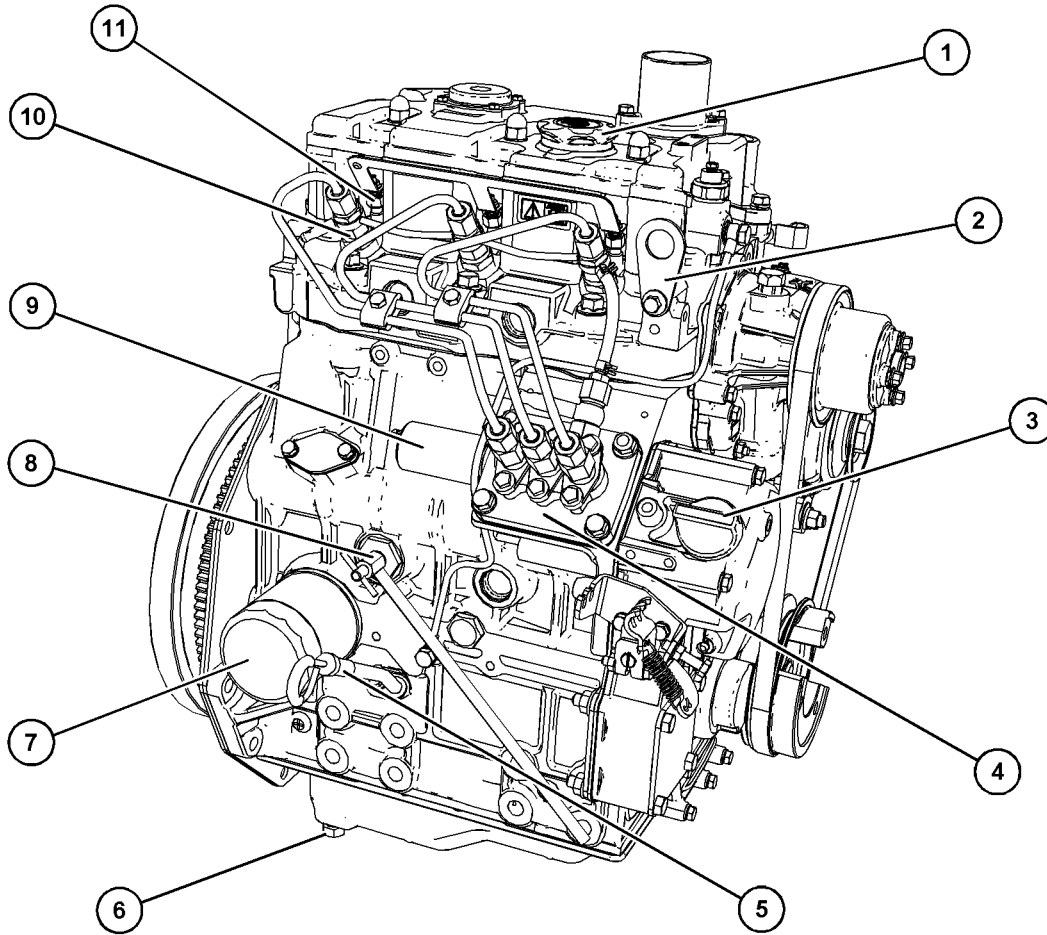

Illustration 5

g06577893

#### Typical example

- |                                |                          |                    |
|--------------------------------|--------------------------|--------------------|
| (1) Top oil filler cap         | (5) Oil gauge (Dipstick) | (9) Stop solenoid  |
| (2) Front lifting eye          | (6) Oil drain plug       | (10) Fuel injector |
| (3) Low mounted oil filler cap | (7) Oil filter           | (11) Glow plug     |
| (4) Fuel injection pump        | (8) Coolant drain        |                    |

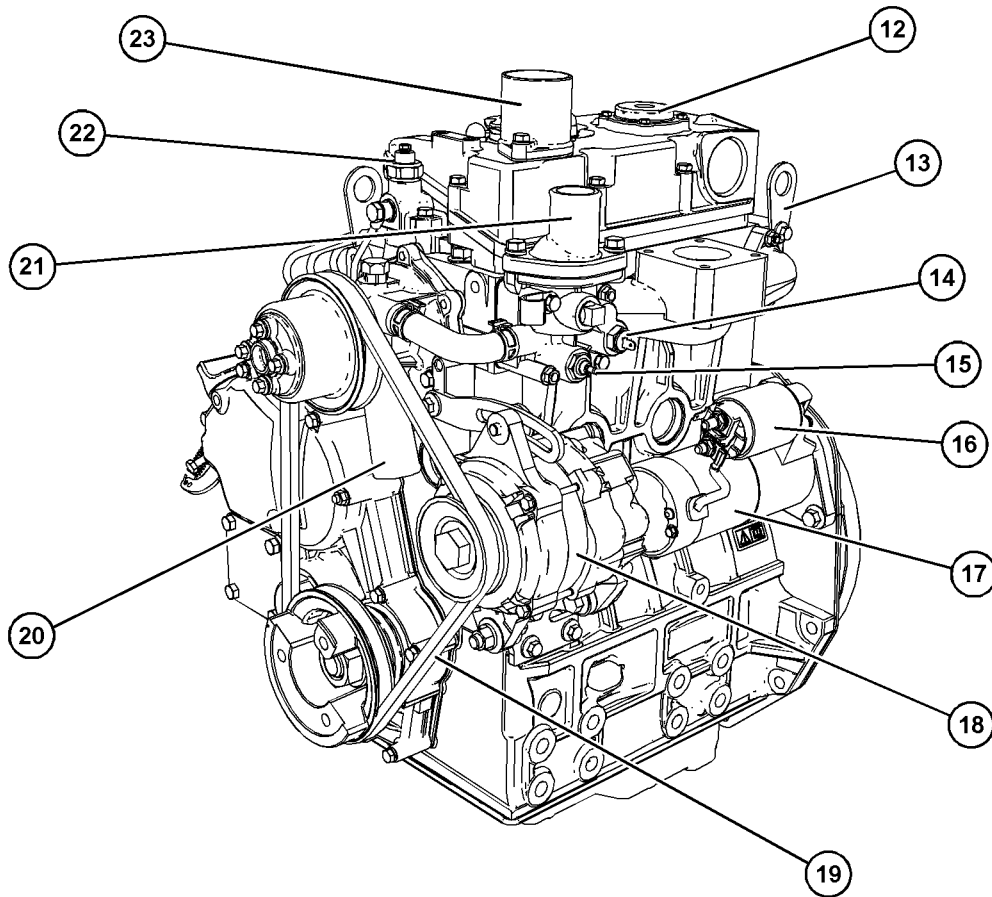

Illustration 6

g06577902

Typical example

- |                                 |                                  |                                |
|---------------------------------|----------------------------------|--------------------------------|
| (12) Crankcase breather         | (16) Solenoid for starting motor | (20) Coolant intake connection |
| (13) Rear lifting eye           | (17) Starting motor              | (21) Coolant outlet            |
| (14) Coolant temperature switch | (18) Alternator                  | (22) Oil pressure switch       |
| (15) Coolant temperature sensor | (19) Fan belt                    | (23) Air intake                |

## 403J-17 Engine

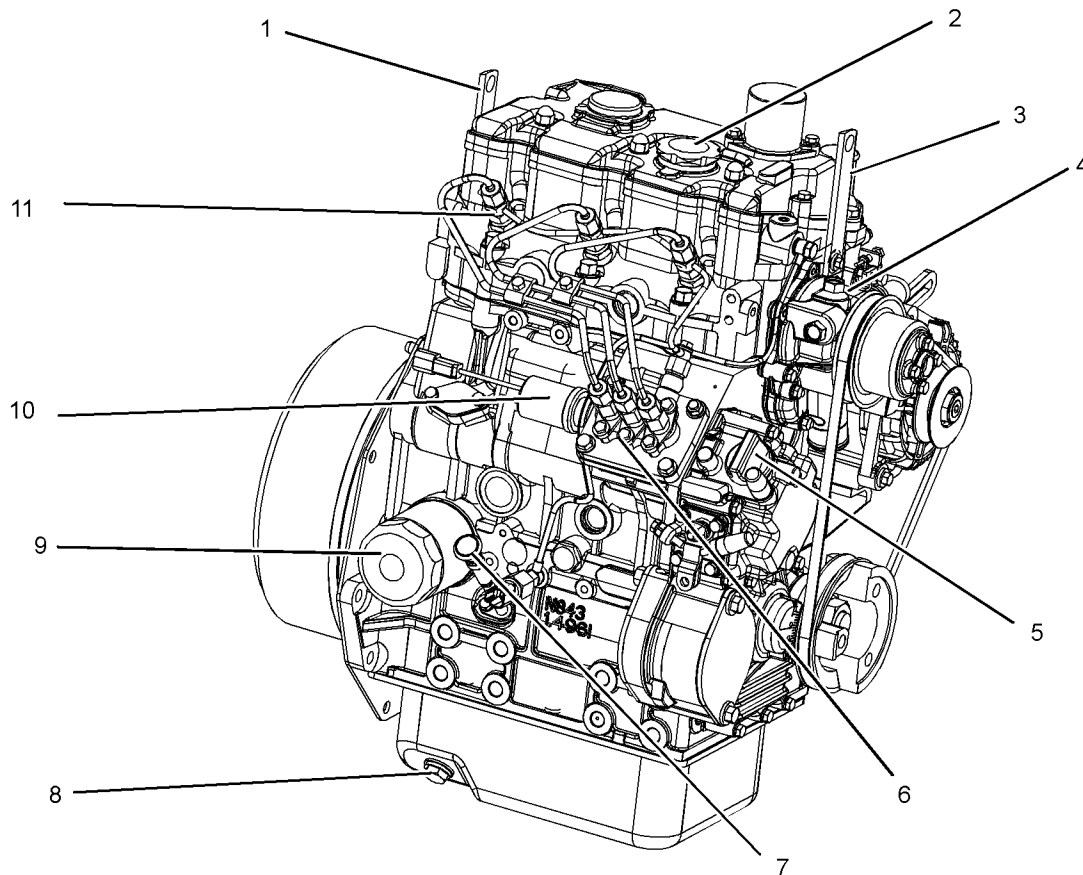

Illustration 7

g03378808

### Typical example

- |                               |                                |                            |
|-------------------------------|--------------------------------|----------------------------|
| (1) Rear lifting eye          | (5) Low mounted oil filler cap | (9) Oil filter             |
| (2) Top engine oil filler cap | (6) Fuel injection pump        | (10) Fuel shutoff solenoid |
| (3) Front lifting eye         | (7) Oil level gauge (Dipstick) | (11) Fuel injector         |
| (4) Water pump                | (8) Oil drain plug             |                            |

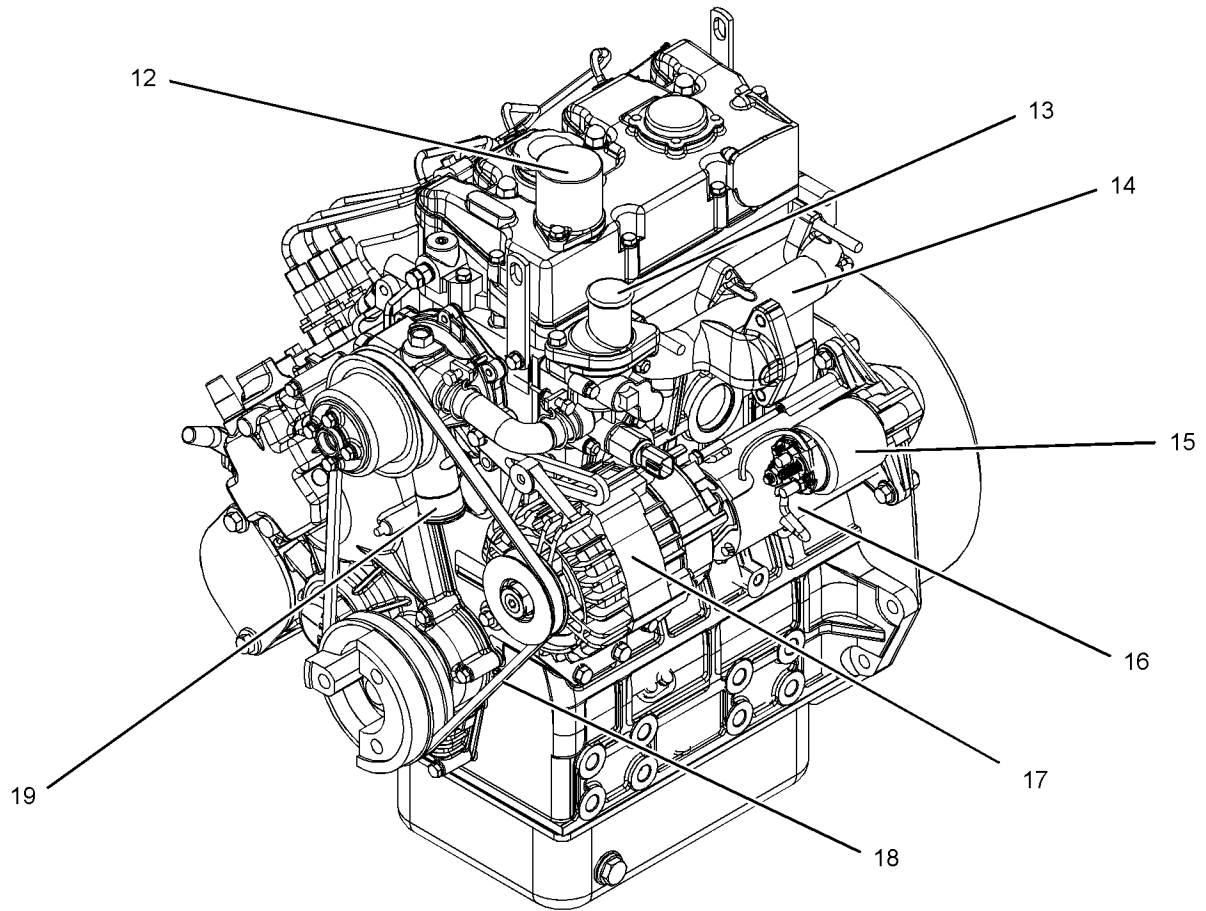

Illustration 8

g03379877

Typical example

- (12) Air intake
- (13) Coolant outlet
- (14) Exhaust manifold

- (15) Starting motor solenoid
- (16) Electric starting motor
- (17) Alternator

- (18) Fan belt
- (19) Coolant intake connection

## 403J-17T Engine

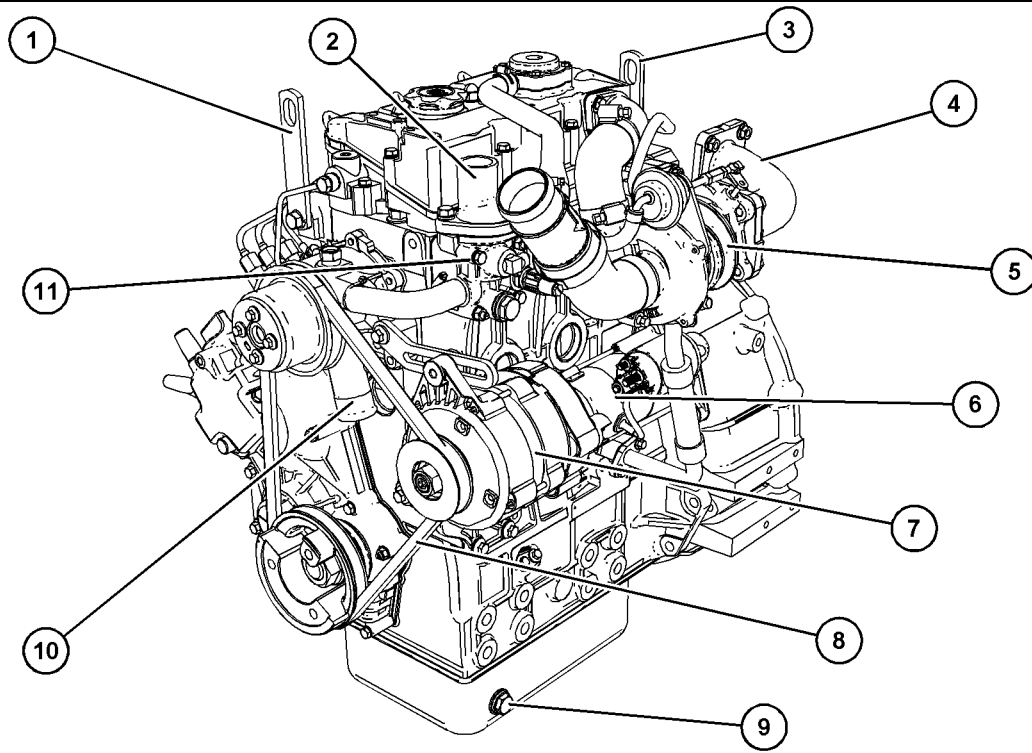

Illustration 9

g06178091

### Typical example

- |                       |                             |  |
|-----------------------|-----------------------------|--|
| (1) Front lifting eye | (5) Turbocharger            | (9) Oil drain plug                       |
| (2) Coolant outlet    | (6) Electric starting motor | (10) Coolant intake                      |
| (3) Rear lifting eye  | (7) Alternator              | (11) Water temperature regulator housing |
| (4) Exhaust elbow     | (8) Drive belt              |  |

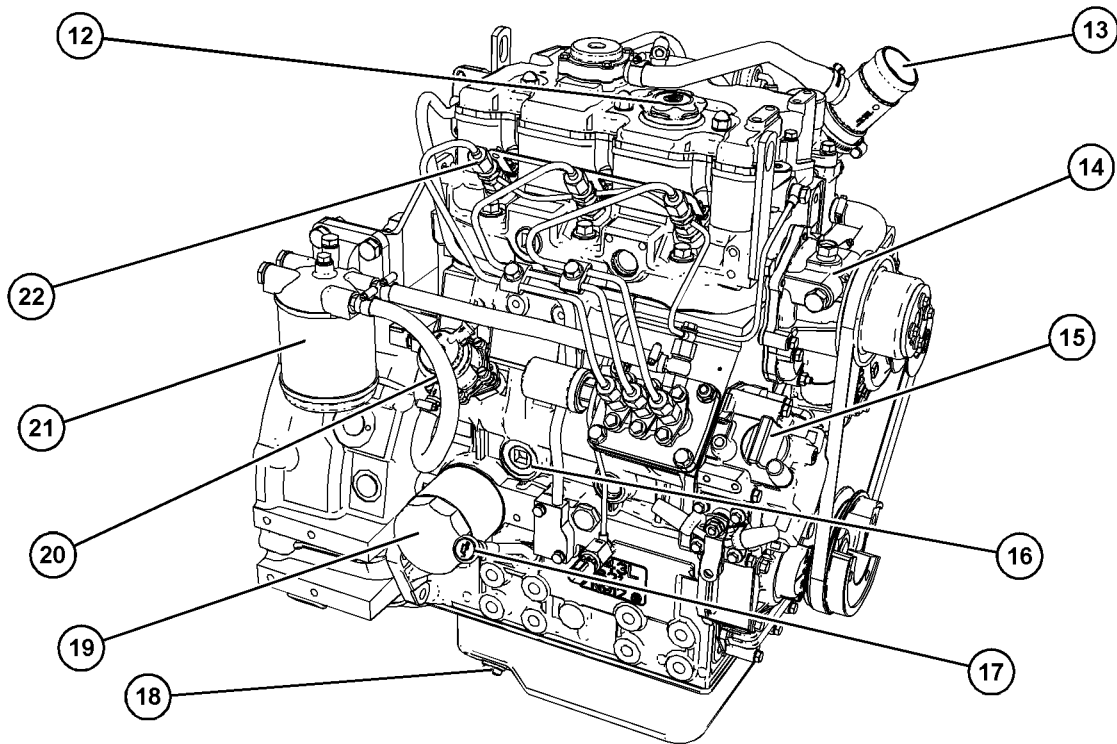

Illustration 10

g06178099

Typical example

- |                         |                           |                            |
|-------------------------|---------------------------|----------------------------|
| (12) Top oil filler     | (16) Cooling drain plug   | (20) Fuel transfer pump    |
| (13) Air intake         | (17) Oil gauge (Dipstick) | (21) Secondary fuel filter |
| (14) Water pump         | (18) Oil drain plug       | (22) Fuel injector         |
| (15) Oil filler (lower) | (19) Oil filter           |                            |

## Fuel System Components

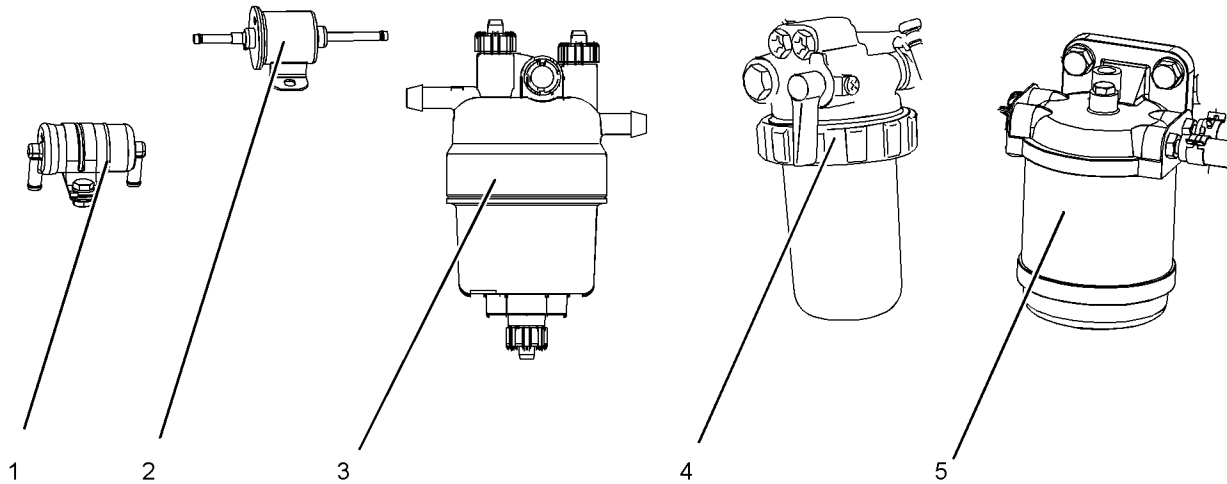

Illustration 11

g03379882

### Typical example

(1) In-line fuel filter  
(2) Electric fuel pump

(3) Primary fuel filter  
(4) Secondary fuel filter (element type)

(5) Secondary fuel filter

**Note:** The electric fuel pump is an option, engines may have a mechanical fuel transfer pump installed.

i02617180

## Fuel System

### General Operation of the Fuel System

Refer to Systems Operation, "General Information" for locations of the components for the fuel system.

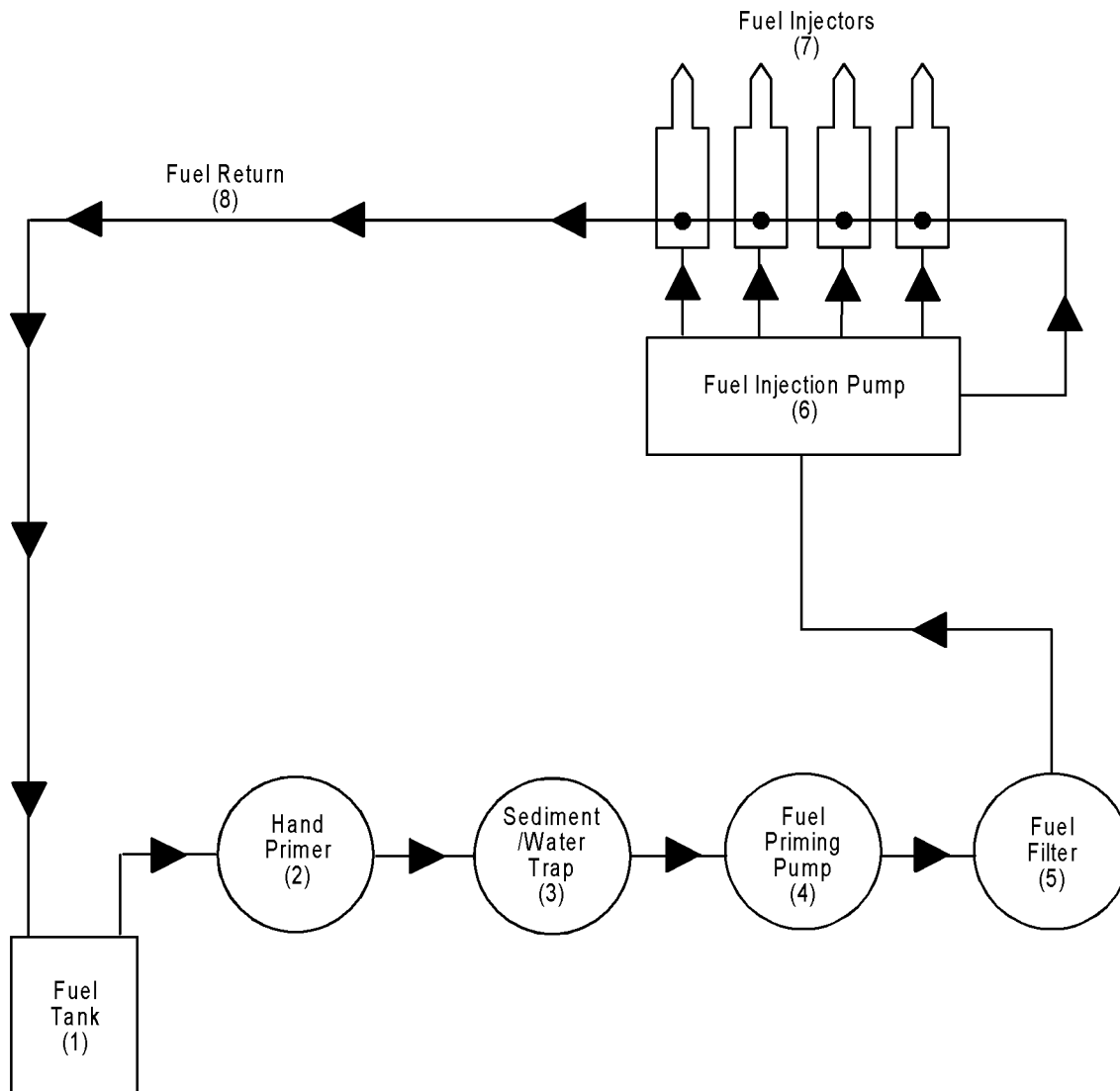

Illustration 12

g01412329

Typical example

- (1) Fuel tank
- (2) Hand primer
- (3) Sediment/water trap
- (4) Fuel priming pump

- (5) Fuel filter
- (6) Fuel injection pump
- (7) Fuel injectors

- (8) Fuel return line from the fuel injection pump and the fuel injectors to the fuel tank

When the engine is cranking, the fuel is pulled from the fuel tank (1) by the fuel priming pump (4). An optional sediment/water trap (3) may be installed between the fuel tank (1) and the fuel priming pump (4). The fuel priming pump forces the fuel through the fuel filter (5) to the fuel injection pump (6).

The fuel filter (5) can also function as a water separator. The fuel filter can be drained through a valve that is located at the bottom of the filter housing.

The fuel injection pump sends fuel at high pressure to each fuel injector (6). The fuel injector sprays fuel into a precombustion chamber which slows the rate of combustion in the cylinder. The following items will result from reducing the rate of fuel combustion: prevention of engine knock, reduction of noise and reduction of emissions.

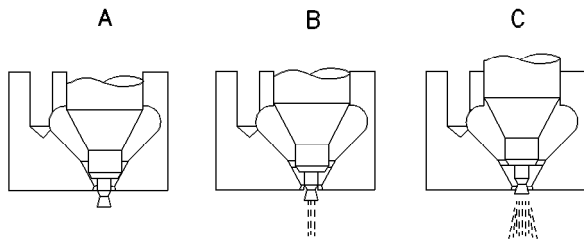

Illustration 13

g00468241

### Phases of operation of the fuel injector

- (A) Closed valve
- (B) Open valve
- (C) Fully open valve

The fuel injector injects fuel into the precombustion chamber at different angles during two phases. Most of the fuel is injected when the valve is fully open (C). This process is called indirect fuel injection. The results are more even combustion and complete combustion of the fuel at a reduced temperature. Improved fuel combustion will increase power output while reducing emissions and reducing fuel consumption.

Excess fuel from the fuel injectors and the fuel injection pump flows through the fuel return line (7) and back to the fuel tank (1). The excess fuel aids the cooling of the fuel injectors. Also, the fuel return line removes any air that is trapped in the fuel injectors and the fuel injection pump.

The fuel injection pump needs fuel for lubrication. If the precision parts of the pump are not adequately lubricated, the components may be easily damaged. The engine must not be started until the fuel injection pump is full of fuel that is free of air.

The system must be primed when any part of the system is drained of fuel. The following list contains examples of both service and repairs when you must prime the system:

- The fuel filter is changed.
- The low pressure fuel line is removed.
- The fuel injection pump is removed.
- The fuel injectors are removed.
- The fuel tank is drained.
- A leak exists in the low pressure side of the fuel system.

In order to release air from the fuel injection pump and the fuel injectors, refer to Testing and Adjusting, "Fuel System - Prime".

## Governor

The fuel rack is connected to the linkage, which controls the fuel injection pump. This linkage is located in the timing case (Front Housing).

These engines have a mechanical governor in order to control engine speed. The governor operates for all engine rpm. The governor weight assembly is installed on the front of the gear of the camshaft. The other components of the governor are installed in the front housing.

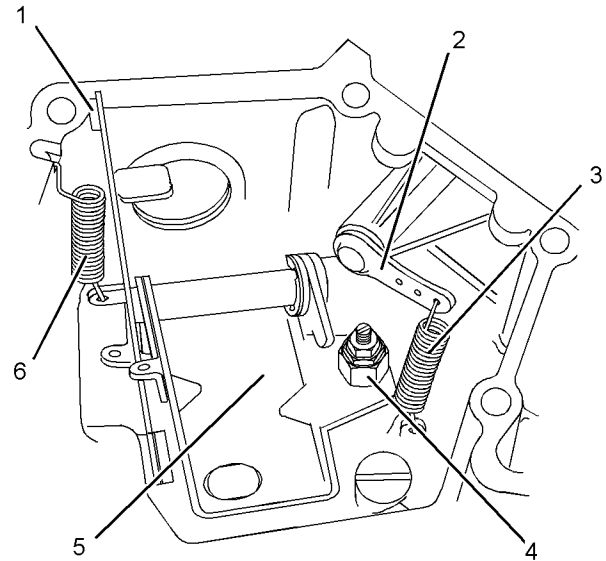

Illustration 14

g01374121

### Governor control mechanism in the front housing without a BCD

- (1) Connection for the linkage to the fuel injection pump
- (2) Control lever
- (3) Lever return spring
- (4) Governor adjustment screw
- (5) Arm
- (6) Start spring

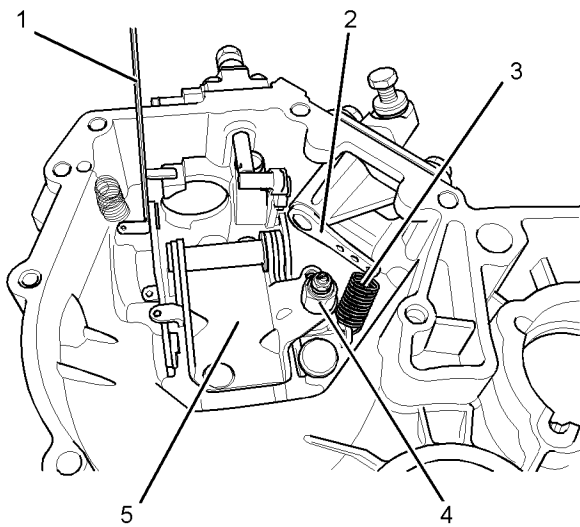

Illustration 15

g01384576

#### Governor control mechanism in the front housing with a BCD

- (1) Connection for the linkage to the fuel injection pump
- (2) Control lever
- (3) Governor main spring
- (4) Angleich
- (5) Governor lever
- (6) Start spring

The movement of the governor weight assembly is transferred to the fuel rack on the fuel injection pump by the control lever (2), the governor lever (5) and the linkage to the fuel injection pump. The governor main spring (3) connects the governor lever to the control lever. The governor main spring controls the movement of the governor weight assembly on the camshaft. When the angle of the control lever changes, the tension on the governor main spring changes. This action controls the linkage to the fuel rack on the fuel injection pump, which controls the engine rpm.

The maximum fuel adjustment screw is mounted in the front housing. This adjustment regulates the fuel injection at high engine rpm. This adjustment should only be made by personnel with the correct training.

The fuel injection pump timing, the low idle, and the high idle are preset at the factory. Adjustments to the pump timing and idle rpm should only be made by personnel that have had the correct training. The timing for the fuel injection pump should only change if the camshaft or the cylinder block are replaced. The fuel injection pump timing should not change if the fuel injection pump is reinstalled with a shim that is the same size.

The fuel rack automatically returns to the excess fuel position when the engine is stopped. The excess fuel position aids the cold starting of the engine.

A spring connects the linkage to the fuel injection pump and mechanical stop control (2). When the engine is first started, the spring automatically increases the fuel flow to the cylinders.

#### Boost Compensation Device for Turbocharged Engines (if equipped)

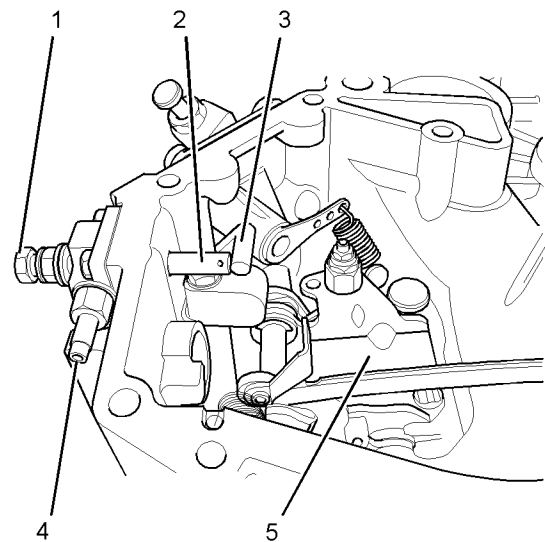

Illustration 16

g01412342

#### Boost Compensation Device (BCD)

- (1) Adjustment screw
- (2) Diaphragm piston
- (3) Stopper
- (4) Intake manifold pressure inlet
- (5) Governor lever

If equipped, the Boost Compensation Device (BCD) can be installed on turbocharged engines. The BCD prevents overfuelling and the production of black smoke during acceleration from low idle.

When the engine is accelerated from a low rpm, the governor lever (5) on the fuel rack comes into contact with the BCD fuel stopper (3) in order to prevent excessive movement of the governor lever. This prevents overfuelling.

As the engine rpm increases, the increased intake manifold pressure is felt on the diaphragm in the BCD. As the BCD fuel stopper is moved by the diaphragm piston, the governor lever is allowed to operate over the full range.

## Fuel Injection Pump

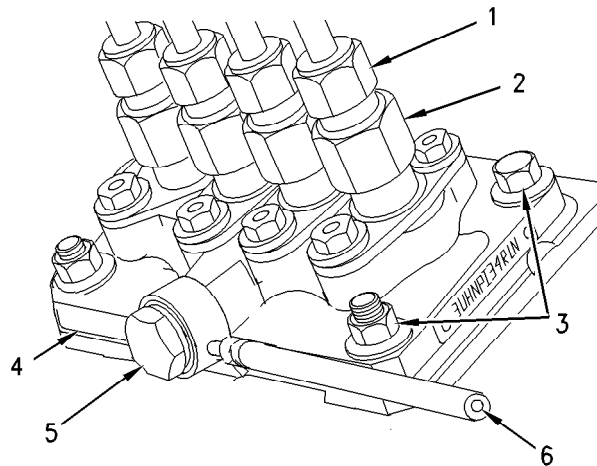

Illustration 17

g00746909

### Fuel injection pump (typical example)

- (1) Fuel line to the fuel injectors
- (2) Fuel delivery valve
- (3) Nuts and setscrews for mounting the fuel injection pump to the cylinder block
- (4) Shim
- (5) Vent screw for the fuel injection pump
- (6) Fuel flow from the fuel transfer pump

The electric fuel shutoff solenoid must be energized in order for fuel to flow through the system.

The fuel injection pump is a cassette type pump. The cassette type pump contains the following components: fuel delivery valves, fuel rack and pushrods. The fuel injection pump is installed directly into the cylinder block.

The part number and code letters for the fuel injection pump are stamped on the front of the pump.

The fuel injection pump is a pressurized system that is totally enclosed. The pump sends the correct amount of fuel under high pressure at the correct time through the fuel injectors to the individual cylinders. The fuel injection occurs near the end of the compression stroke. The fuel injection pump regulates the amount of fuel that is delivered to the fuel injectors. This action controls the engine rpm by the governor setting or the position of the throttle control.

The camshaft is driven by the idler gear in the timing case. Lobes on the camshaft cause the pushrod for each cylinder to reciprocate. The reciprocating motion first draws the fuel. The reciprocating motion then pressurizes the fuel. A fuel delivery valve (2) for each cylinder acts as a check valve in order to prevent a loss of pressure to the fuel injector.

The correct operation of the fuel injection pump requires the pump to be completely full of fuel and empty of air. When the vent screw (5) is loosened, air can escape from the fuel injection pump.

The fuel injection pump will lubricate the components during operation.

## Fuel Injectors

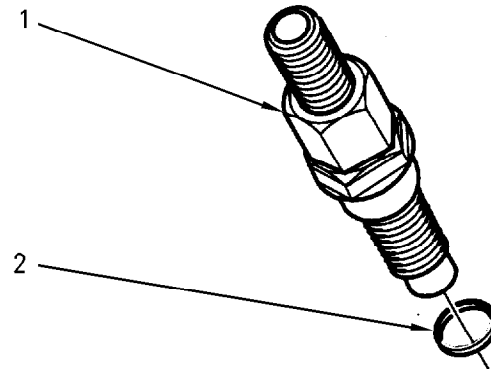

Illustration 18

g00836660

- (1) Fuel injector
- (2) Sealing washer

The sealing washer (2) helps to prevent blowby. The sealing washer also sets the projection of the fuel injector (1) into the precombustion chamber. This projection affects the time that is required for combustion in the cylinder. If the projection is excessive, engine knock can occur at high rpm.

**Note:** When a fuel injector (1) is installed in the cylinder head, a new sealing washer (2) should be installed.

The operating pressure of the fuel injector is set and tested at the factory. Refer to Specifications, "Fuel Injectors" for the pressure settings of the fuel injector.

During operation, extra fuel is used as coolant and lubricant for components of the fuel injector.

## Fuel Priming Pump

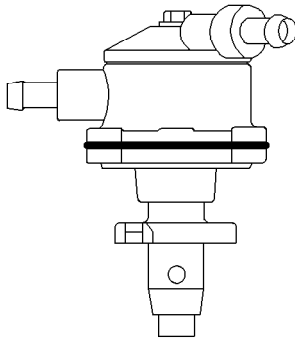

Illustration 19

g00909677

The fuel priming pump creates a vacuum in order to force fuel from the fuel tank. Pressure is created in order to pump the fuel to the fuel injection pump. The diaphragm prevents the leakage of the fuel into the cylinder block. The diaphragm creates part of the pumping action of the fuel priming pump. The outlet valve and the inlet valve operate as check valves.

A lobe on the camshaft causes the arm to move up and down. When the arm moves down, the diaphragm assembly moves down. This down movement increases the size of the chamber above the diaphragm assembly. This suction opens the inlet valve which draws fuel into the chamber above the diaphragm assembly to the fuel priming pump.

When the arm moves up, the diaphragm assembly moves up. This up movement pressurizes the chamber above the diaphragm assembly. This pressure opens the outlet valve which allows fuel to flow out of the fuel priming pump toward the fuel injection pump.

## Glow Plugs

Each cylinder has a glow plug in order to aid the cold starting of the engine. The glow plugs may be energized by two different methods:

- The ignition switch is moved to the auxiliary position (if equipped).
- The starting aid switch (if equipped) is moved to the ON position.

In cold ambient temperatures, energizing the glow plugs for six seconds will heat the cylinder sufficiently for easy starting of the engine.

i08146376

## Air Inlet and Exhaust System

Naturally aspirated engines pull outside air through an air cleaner directly into the inlet manifold. The air flows from the inlet manifold to the engine cylinders. The fuel is mixed with the air in the engine cylinders. After the fuel combustion occurs in the engine cylinder, the exhaust gases flow directly to the outside air through the exhaust manifold and the exhaust system.

Turbocharged engines pull outside air through an air cleaner into the air intake of the turbocharger. The suction is caused by the turbocharger compressor wheel. Then, the turbocharger compressor wheel compresses the air. The air flows through the inlet manifold which directs an even distribution of the air to each engine cylinder. Air is pulled into the engine cylinder during the intake stroke of the piston. Then, the air is mixed with fuel from the fuel injectors.

Each piston makes four strokes:

### 1. Intake

Air is drawn into the cylinder through the open inlet valve.

### 2. Compression

On the compression stroke, the piston moves back up the cylinder and the inlet valves close. The cool air is compressed further. This additional compression generates more heat.

### 3. Power

Fuel is sprayed into the engine by the fuel injection nozzle. The mixture of air and fuel ignites at the top of the compression stroke. The expansion of gases from the combustion forces the piston downward. This force creates the power of the engine.

### 4. Exhaust

The piston moves upward to force the gases of combustion from the cylinder through the open exhaust valve.

The sequence of the strokes by all the pistons in all the engine cylinders provides constant air flow from the air inlet system during the engine operation.

## Turbocharger

A turbocharger increases the temperature and the density of the air that is sent to the engine cylinder. This condition causes a lower temperature of ignition to develop earlier in the compression stroke. The compression stroke is also timed in a more accurate way with the fuel injection. Surplus air lowers the temperature of combustion. This surplus air also provides internal cooling.

A turbocharger improves the following aspects of engine performance:

- Power output is increased.
- Engine torque is increased.
- Engine efficiency is increased.

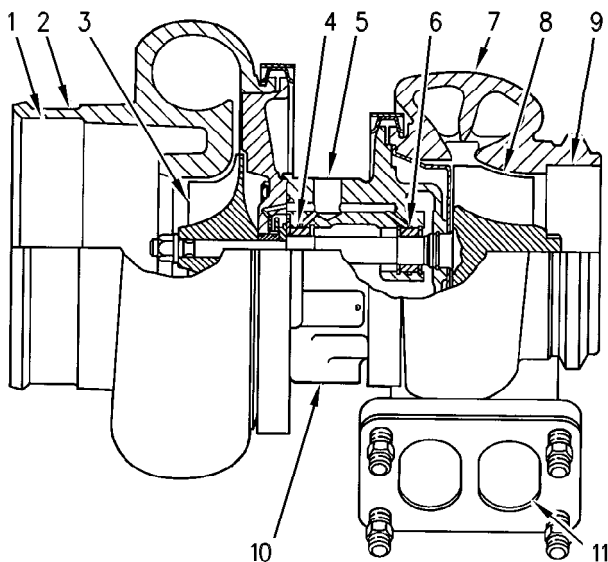

Illustration 20

g00302786

### Components of a turbocharger (typical example)

- (1) Air intake
- (2) Compressor housing
- (3) Compressor wheel
- (4) Bearing
- (5) Oil inlet port
- (6) Bearing
- (7) Turbine housing
- (8) Turbine wheel
- (9) Exhaust outlet
- (10) Oil outlet port
- (11) Exhaust inlet

A turbocharger is installed between the exhaust and intake manifolds. The turbocharger is driven by exhaust gases which flow through the exhaust inlet (11). The energy of the exhaust gas turns the turbine wheel (8). Then, the exhaust gas flows out of the turbine housing (7) through the exhaust outlet (9).

The turbine wheel (8) and the compressor wheel (3) are installed on the same shaft. Therefore, the turbine wheel (8) and the compressor wheel (3) rotate at the same rpm. The compressor wheel is enclosed by the compressor housing (2). The compressor wheel compresses the intake air. The intake air flows into the engine cylinders through the inlet valves of the cylinders.

The oil from the main gallery of the cylinder block flows through the oil inlet port (5) to lubricate the turbocharger bearings (4) and (6). The pressurized oil passes through the bearing housing of the turbocharger. The oil is returned through the oil outlet port (10) to the oil pan.

The turbocharger has a wastegate. The wastegate is controlled by the boost pressure. This allows some of the exhaust gases to bypass the turbine wheel at higher engine speeds. The wastegate is a type of flapper valve that automatically opens at a preset level of boost pressure to allow the exhaust gas to flow around the turbine. The wastegate allows the design of the turbocharger to be more effective at lower engine speeds.

## Cylinder Head And Valves

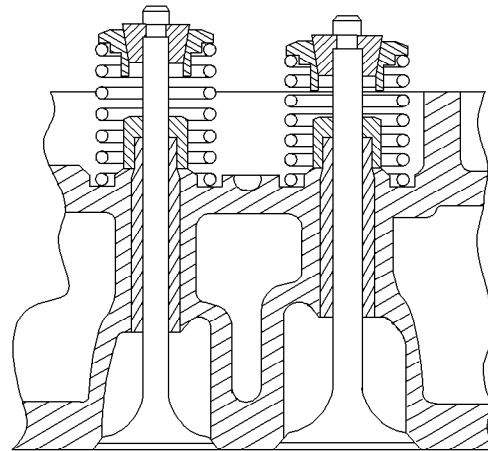

Illustration 21

g00905459

### Cross section of the inlet and exhaust valves in the cylinder head (typical example)

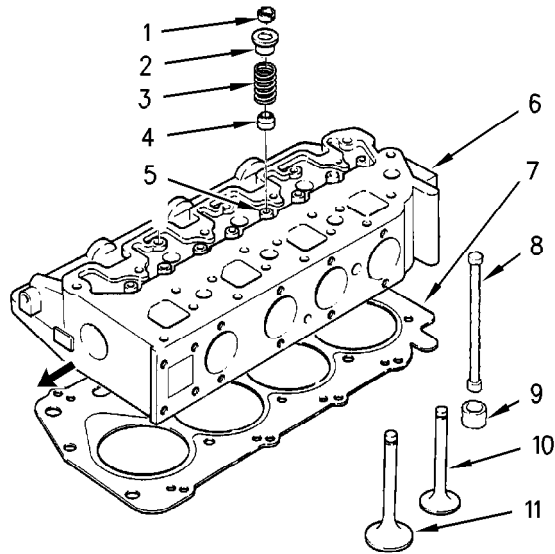

Illustration 22

g00905464

### Cylinder head and valves (typical example)

- (1) Collets
- (2) Valve spring retainer
- (3) Valve spring
- (4) Valve seal
- (5) Valve guide
- (6) Cylinder head
- (7) Cylinder head gasket
- (8) Pushrod
- (9) Lifter
- (10) Exhaust valve
- (11) Inlet valve

The valves and the rocker shaft assembly control the flow of air into the cylinders and out of the cylinders during engine operation. The cylinder head assembly has two valves for each cylinder. Each valve has one valve spring (3). The ports for the inlet valve (11) and the exhaust valve (10) are on the left side of the cylinder head.

The valve moves along a steel valve guide (5).

The inlet valve and the exhaust valve are opened and closed by the rotation and movement of the following components:

- Crankshaft
- Idler gear
- Camshaft
- Valve lifters
- Pushrods
- Rocker arms
- Valve springs

The camshaft gear is driven by the idler gear. The camshaft gear, the idler gear, and the crankshaft gear are timed together. When the camshaft turns, the valve lifters are moved up and down. The pushrods move the rocker arm levers. The rocker arm levers make the inlet valves and the exhaust valves open and close. This is in sequence with the firing order of the engine. The valve springs force the valves back to the closed position.

### Crankcase Breather

The valve mechanism cover contains a closed crankcase breather assembly. The gases in the valve cover, which are caused by blowby, pass from the crankcase to the inlet manifold. The breather is sealed from the outside air by a diaphragm. Above the diaphragm, the cover is vented to the outside air by a small vent hole so that pressure does not build up.

i02181303

## Lubrication System

The lubrication system contains the following components:

- Oil pump
- Engine oil relief valve
- Engine oil cooler (turbocharged engines)
- Oil filter
- Oil pan
- Oil strainer and suction pipe
- Oil level gauge
- Oil pressure switch
- An oil supply line to the cylinder head

The oil pump is contained within the idler gear. The engine oil relief valve is installed in the right side of the cylinder block.

The oil filter is a spin-on filter that is disposable.

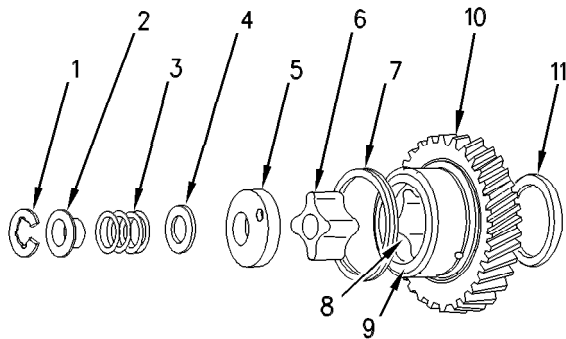

Illustration 23

g00458938

### Idler gear and components of the oil pump

- (1) Snap ring
- (2) Collar
- (3) Spring
- (4) Shim
- (5) Oil pump cover
- (6) Inner rotor
- (7) Spring
- (8) Outer rotor
- (9) Bush
- (10) Idler gear
- (11) Thrust washer

Pressure for the lubrication system is supplied by an engine oil pump which uses rotors. The oil pump is part of the idler gear (10). The idler gear is driven by the crankshaft gear.

The oil pump has an inner rotor (6) and an outer rotor (8). The axes of rotation of the rotors are off-center relative to each other. There is a pin that is inserted through a hole in the oil pump cover (5) into the outer rotor. The pin functions as a key in order to keep the outer rotor in a fixed position with the idler gear.

The outer rotor is pressed into the bush (9). The bush is pressed into the idler gear (10).

The inner rotor has four lobes which mesh with the five lobes of the outer rotor. When the outer lobe rotates, the distance increases between the lobes of the outer rotor and the lobes of the inner rotor in order to create suction. Then, the space between the lobes is filled with oil. When the distance decreases between the lobes, pressure is created. This pressure forces the oil into the chamber for the engine oil relief valve.

Lubricating oil from the oil pan flows through a strainer and a line to the suction side of the engine oil pump. The suction side is in the timing gear case. The lubricating oil flows from the outlet side of the pump to a relief valve. The relief valve is installed on the right side of the cylinder block. The lubricating oil, which flows around the relief valve, flows to the oil filter.

When the engine rpm increases, the flow rate of the oil pump increases. The increase in the flow rate from the oil pump causes the pressure to increase. The relief valve opens if the oil pressure is too high. When the oil pressure on the plunger of the relief valve is greater than the force of the spring in the relief valve, the relief valve opens. The lubricating oil which flows through the relief valve is returned to the oil pan.

The oil filter is installed on the right side of the cylinder block. Turbocharged engines have an engine oil cooler that is installed between the oil filter and the cylinder block. The oil flows through the oil filter into the main oil gallery. The main oil gallery is drilled through the total length of the right side of the cylinder block.

Oil flows from the main oil gallery through an externally mounted oil supply line to the cylinder head. An oil pressure switch measures the oil pressure at this location. This oil lubricates the rocker arm assembly. The oil passes through the rocker shaft to the bore of each rocker arm lever. Then, the oil flows from the rocker arm levers through holes that are located in the top of the rocker arm levers. The valve stems, the valve springs, and the tappets are lubricated by the splash and the mist of the oil.

The lubricating oil flows through drilled holes in the main oil gallery to passages in the main journals of the crankshaft. Then, the oil flows to the main bearings of the crankshaft. Also, the oil flows through passages in the crankshaft to the large end bearings of the connecting rods. The piston bearings, the pistons, and the cylinder bores are lubricated by the splash and the mist of the oil.

A hole is located in the bore of each main bearing. This hole allows oil to flow through passages that lubricate the journals of the camshaft for the valves. The bearing for the front journal receives oil from the front main journal of the crankshaft. The camshaft is lubricated by the splash of the oil.

The timing gears are lubricated by the splash of the oil. Lubricating oil from the timing case returns to the oil pan.

i07188133

## Cooling System

The coolant system contains the following components:

- Radiator
- Pressure cap for the radiator
- Fan for the radiator
- Drive pulley (if equipped) for the fan
- Water pump

- Drive pulley for the water pump
- Water temperature regulator
- Housing for the water temperature regulator
- Coolant temperature switch

The coolant flows from the bottom of the radiator to the centrifugal water pump. The water pump is installed on the cylinder block above the timing case. The water pump is driven by a pulley. The crankshaft pulley turns a belt which drives the pulley of the water pump.

The water pump forces the coolant to flow to the water temperature regulator. When the engine is cold, the water temperature regulator is closed. Then, the coolant flows directly into the cylinder head. When the engine warms, the water temperature regulator begins to open. Then, the regulator allows some of the coolant to flow to the top of the radiator.

The regulator opens fully when the engine reaches the normal operating temperature. When the regulator is fully open, the flow to the radiator is the maximum. However, the regulator does not close the flow of coolant into the cylinder head.

Coolant flows continuously through the cylinder head and the top of the cylinder block. This coolant flows into the back of the water pump from the cylinder block. This coolant then mixes with the coolant that is pumped from the radiator by the water pump.

The water temperature regulator maintains the correct engine temperature by adjusting the direct flow of coolant to the top of the radiator. The coolant is cooled by the radiator. Heat is removed from the coolant by cooler air which passes over the radiator fins. The fan causes a high volume of air to flow between the radiator fins to provide sufficient cooling. The coolant flows from the radiator through the bottom hose to the coolant pump.

The engine has a housing for the water temperature regulator. The housing is installed on the left side of the cylinder head.

The water temperature regulator housing for the 402J-05 and 403J-07 engines is mounted horizontally. The water temperature regulator housing for all other engine models is mounted vertically.

i08146436

## Basic Engine

### Cylinder Head and Block

The cylinder head assembly has one inlet valve and one exhaust valve for each cylinder. Each valve has a single valve spring and a valve seal. The valve and the valve spring are held in position by a valve spring retainer and two collets. The valve seal fits over the top of the valve guide.

The ports for the inlet and for the exhaust valves are on the left side of the cylinder head.

The cylinder block does not have cylinder liners. The cylinder walls are honed.

The valve mechanism cover is made from aluminum. The cover contains the following components:

- A closed breather assembly
- An oil filler cap
- A seal for the face toward the cylinder head
- Holes for four cap nuts
- Holes for two setscrews

The cap nuts are threaded onto studs. The steel studs are threaded into the cylinder head.

The setscrews are threaded onto the cover for the rocker shaft assembly.

The valve mechanism cover contains a crankcase breather. The gases in the valve cover, which are caused by blowby, pass from the crankcase to the inlet manifold.

### Pistons and Connecting Rods

The pistons of the engine have a combustion chamber in the crown of the piston to provide an efficient mix of the fuel and the air.

The piston pin is off-center to reduce the noise level.

The pistons have two compression rings and an oil control ring.

The correct piston height is important to ensure that the piston does not contact the cylinder head. The correct piston height also ensures the efficient combustion of fuel which is necessary to conform to requirements for emissions. The piston must not be machined to obtain the correct piston height.

A piston and connecting rod are matched to each cylinder.

One height of piston is available. Inside the piston is an identification mark. This identification mark faces the right side of the engine. Refer to Systems Operation, Testing and Adjusting, "Piston Height - Inspect" for procedures to measure the piston height.

Identification marks on the connecting rod and the connecting rod cap must align. The identification marks face the right side of the engine.

The main bearing caps have a chamfered edge on one side. The chamfer faces the front of the engine.

## Timing Gear Case and Gears

The timing gear case contains the following components:

- Front oil seal for the crankshaft pulley
- Bearing for the crankshaft gear
- Engine oil pump
- Adjustment screw for setting the maximum fuel position
- Adjustment screw for setting the maximum speed position
- Mechanical stop control
- Linkage for the fuel injection pump
- Fuel Control lever for the governor
- Throttle

The crankshaft for the 402J-05 engine has two main journal bearings. The crankshafts for the 403J-07, 403J-11, 403J-11T, 403J-15, 403J-17, and 403J-17T engines have four main journal bearings. The crankshaft has a front bearing that is pressed in the cylinder block.

**Note:** The 402J-05, 403J-07, and 403J-11 engines have aluminum bearing caps on the rear main bearing that act as thrust washers.

The thrust washers are hemispherical in shape.

The 403J-11T and 403J-15 engines have two thrust washers that are on both sides of the bottom half of holder for the rear main bearing.

**Note:** The thrust washers on the 403J-11T engine are installed into the cast iron holder for the rear main bearing.

The 403J-17 and 403J-17T engines have three thrust washers that are installed into the holder for the rear main bearing.

The crankshaft has a front oil seal and a rear oil seal.

The timing case is made of aluminum. The timing gears are stamped with timing marks to ensure the correct assembly of the gears.

The number one piston is at the top center position on the compression stroke when the following timing marks are aligned:

- Idler gear, crankshaft gear, and camshaft gear
- Crankshaft pulley and timing case

The crankshaft gear turns the idler gear which then turns the camshaft gear.

The idler gear contains the oil pump. The idler gear turns the gear for the tachometer.

The crankshaft pulley drives the pulley on the water pump and the pulley which drives the alternator.

i02996119

## Electrical System

### Engine Electrical System

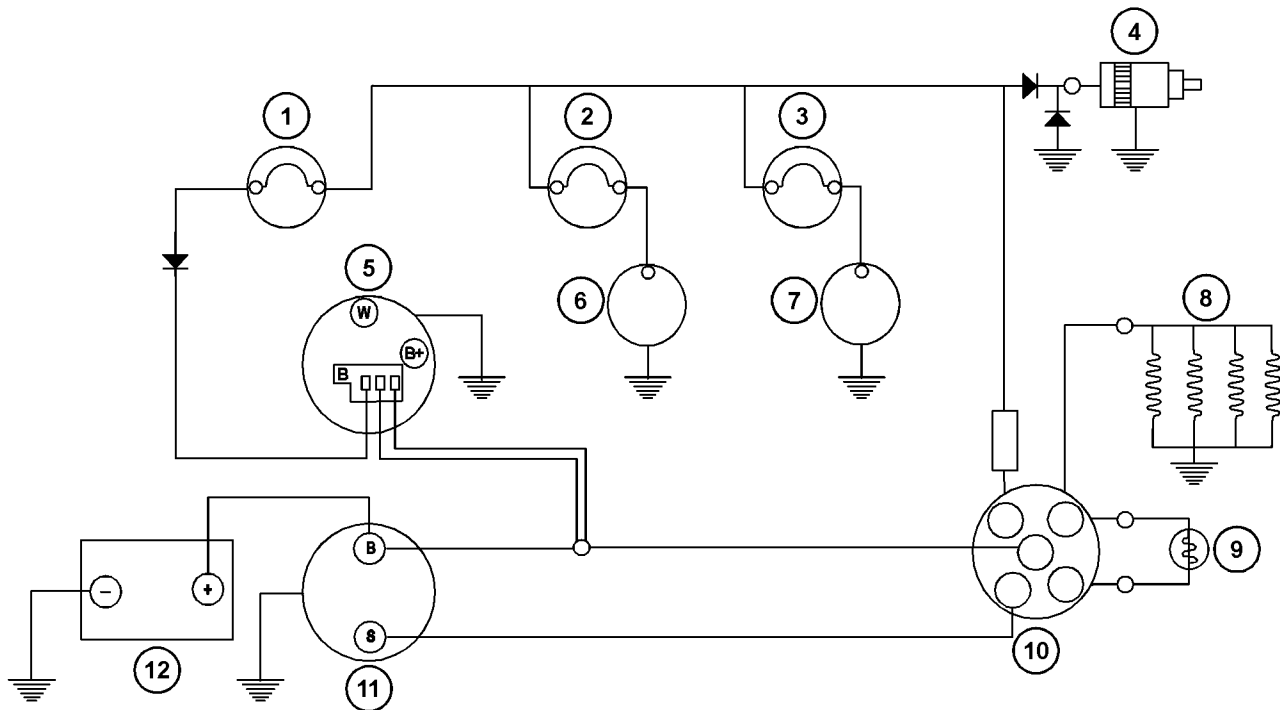

Illustration 24

g01339089

- |  |                                |                              |
|--|--------------------------------|------------------------------|
| (1) Warning lamp (alternator)          | (5) Alternator                 | (9) Signal for glow plugs    |
| (2) Warning lamp (oil pressure)        | (6) Engine oil pressure switch | (10) Ignition switch         |
| (3) Warning lamp (coolant temperature) | (7) Coolant temperature switch | (11) Electric starting motor |
| (4) Fuel shutoff solenoid              | (8) Glow plugs                 | (12) Battery                 |

The electrical system has two separate circuits.

- Charging circuit
- Starting circuit

Some of the electrical system components are used in more than one circuit. The following items are common in each of the circuits:

- Battery
- Circuit breaker
- Cables
- Wires for the battery

The charging circuit is in operation when the engine is running. An alternator converts mechanical energy to electrical energy for the charging circuit. A voltage regulator in the circuit controls the electrical output in order to keep the battery at full charge.

#### NOTICE

The disconnect switch, if equipped, must be in the ON position in order to let the electrical system function. There will be damage to some of the charging circuit components if the engine is running with the disconnect switch in the OFF position.

If the engine has a disconnect switch, the starting circuit can operate only after the disconnect switch is put in the "ON" position.

The starting switch is in operation only when the start switch is activated.

The charging circuit is connected through the ammeter. The starting circuit is not connected through the ammeter.

---

## **Automatic Shutdown System**

**Wiring Diagram for a 14 and 15 Amp Alternator**

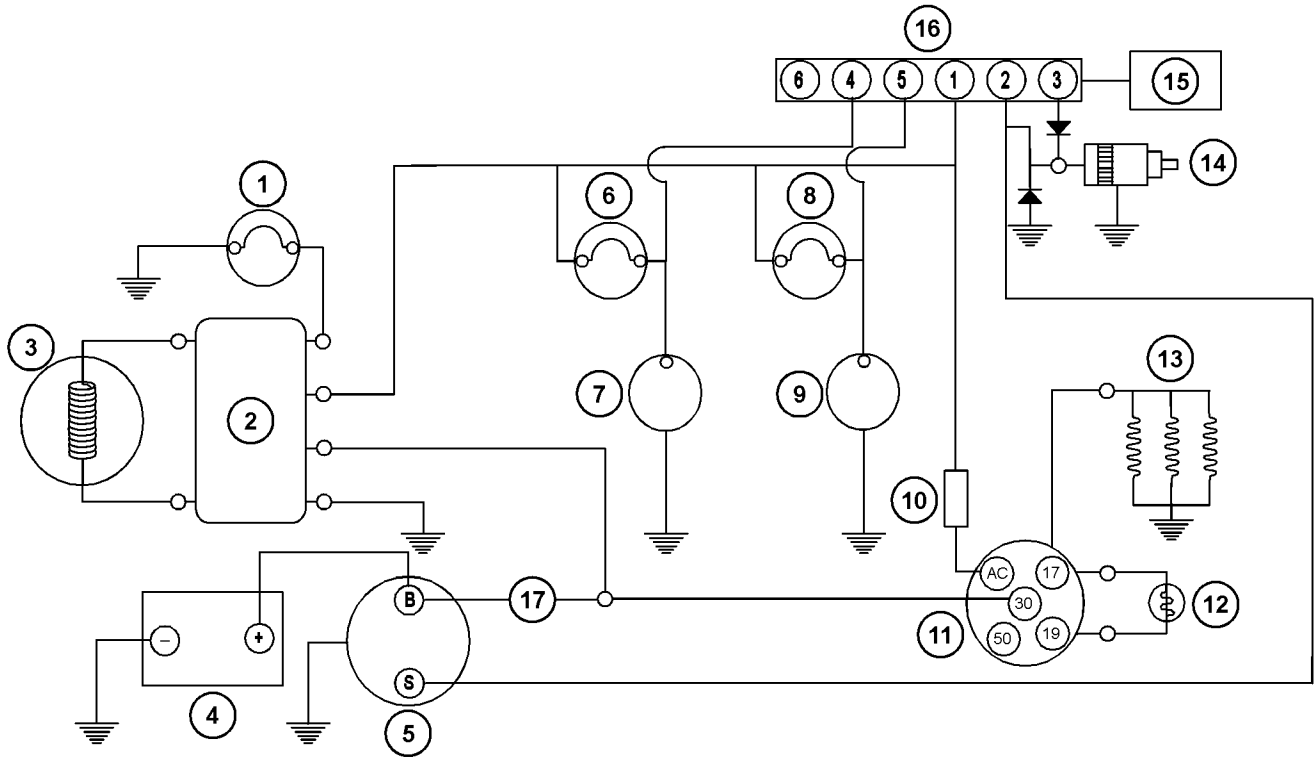

Illustration 25

g01339109

- |                                 |  |                                |
|---------------------------------|--|--------------------------------|
| (1) Warning lamp (alternator)   | (7) Engine oil pressure switch         | (13) Glow plugs                |
| (2) Regulator                   | (8) Warning lamp (coolant temperature) | (14) Fuel shutoff solenoid     |
| (3) Alternator                  | (9) Coolant temperature switch         | (15) Automatic shutdown device |
| (4) Battery                     | (10) Fuse                              | (16) Electrical connector      |
| (5) Electric starting motor     | (11) Ignition switch                   | (17) Delay fuse                |
| (6) Warning lamp (oil pressure) | (12) Signal for glow plugs             |                                |

### Wiring Diagram for a 40 Amp Alternator

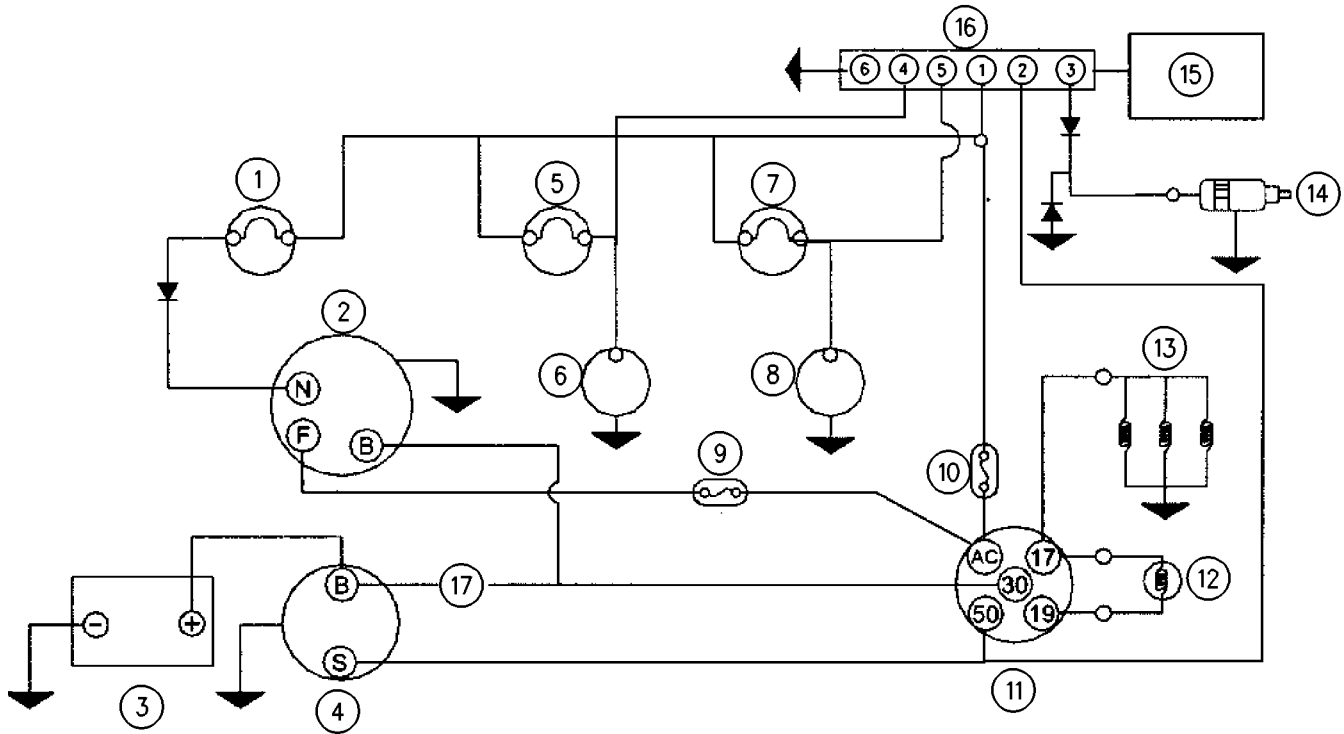

Illustration 26

g00916844

- |                                 |  |                                |
|---------------------------------|--|--------------------------------|
| (1) Warning lamp (alternator)   | (7) Warning lamp (coolant temperature) | (13) Glow plugs                |
| (2) Alternator                  | (8) Coolant temperature switch         | (14) Fuel shutoff solenoid     |
| (3) Battery                     | (9) Fuse                               | (15) Automatic shutdown device |
| (4) Electric starting motor     | (10) Fuse                              | (16) Electrical connector      |
| (5) Warning lamp (oil pressure) | (11) Ignition switch                   | (17) Delay fuse                |
| (6) Engine oil pressure switch  | (12) Signal for glow plug              |                                |

**Wiring Diagram for a 55 Amp Alternator**

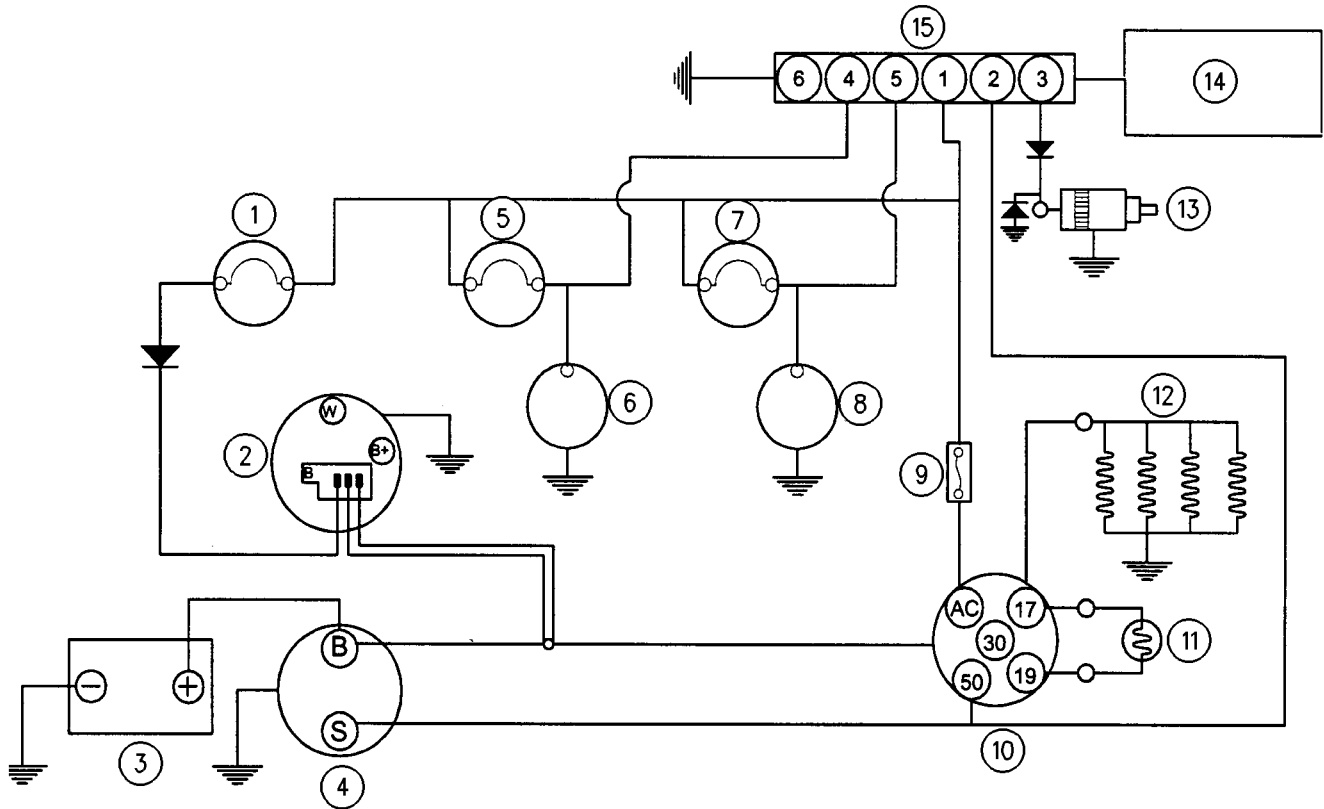

Illustration 27

g00916845

- (1) Warning lamp (alternator)
- (2) Alternator
- (3) Battery
- (4) Electric starting motor
- (5) Warning lamp (oil pressure)

- (6) Engine oil pressure switch
- (7) Warning lamp (coolant temperature)
- (8) Coolant temperature switch
- (9) Fuse
- (10) Ignition switch

- (11) Signal for glow plug
- (12) Glow plugs
- (13) Fuel shutoff solenoid
- (14) Automatic shutdown device
- (15) Electrical connector

## Wiring Diagram for a 65 Amp Alternator and a 85 Amp Alternator

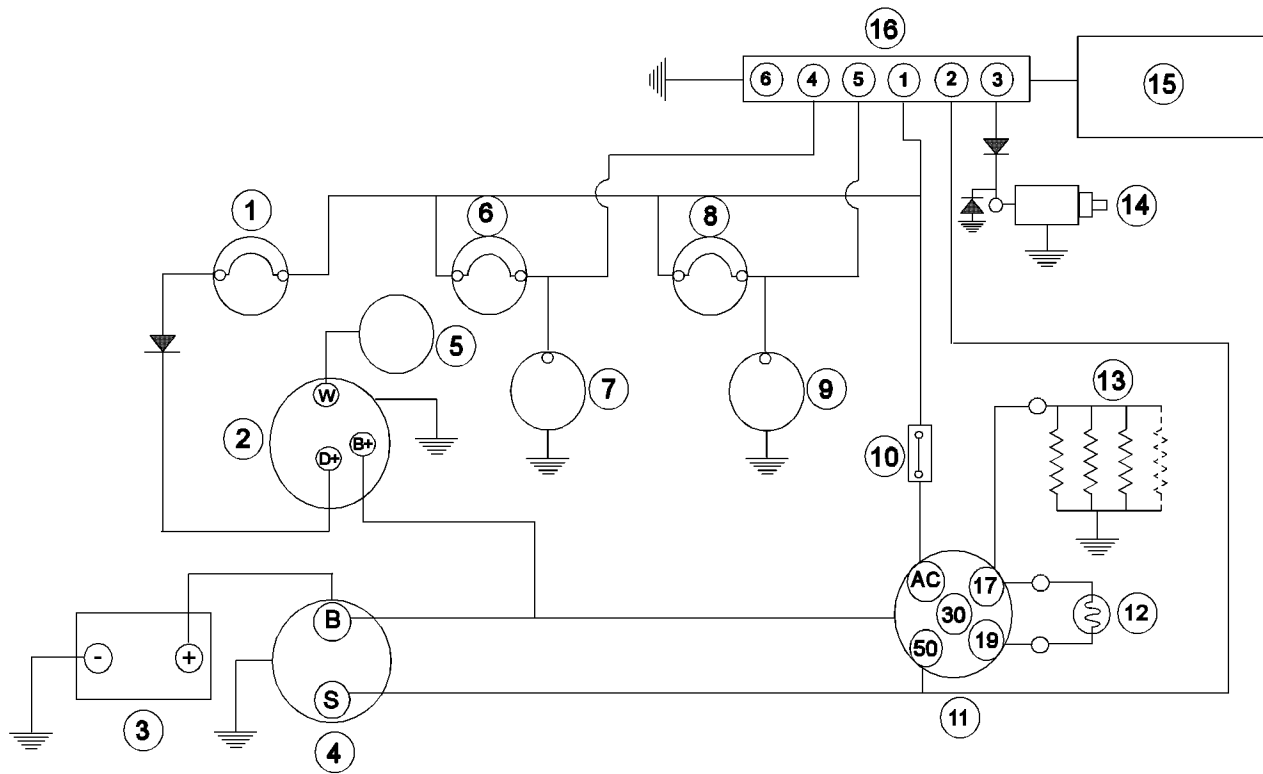
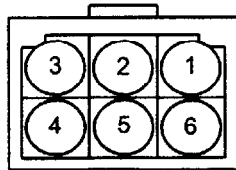

Illustration 28

g01519204

- |                                 |  |                                |
|---------------------------------|--|--------------------------------|
| (1) Warning lamp (alternator)   | (7) Engine oil pressure switch         | (13) Glow plugs                |
| (2) Alternator                  | (8) Warning lamp (coolant temperature) | (14) Fuel shutoff solenoid     |
| (3) Battery                     | (9) Coolant temperature switch         | (15) Automatic shutdown device |
| (4) Electric starting motor     | (10) Fuse                              | (16) Electrical connector      |
| (5) Tachometer                  | (11) Ignition switch                   |                                |
| (6) Warning lamp (oil pressure) | (12) Signal for glow plug              |                                |

## Electrical Connector



Electrical Connector

Illustration 29 g00841411

Connector for the automatic shutdown device (typical example)

- (1) Ignition switch (red wire)
- (2) Ignition switch (orange wire)
- (3) Fuel shutoff solenoid (red and black wire)
- (4) Engine oil pressure switch (brown wire)
- (5) Coolant temperature switch (blue wire)
- (6) Ground (black wire)

## Automatic Shutdown Conditions

The engine will shut down if the following conditions continue for more than ten seconds while you start the engine or for two seconds while you operate the engine:

Coolant temperature exceeds the following values:

All engines . . . . .  $110^{\circ} \pm 3^{\circ}\text{C}$  ( $(230^{\circ} \pm 5^{\circ}\text{F})$ )

Engine oil pressure falls below the following values:

Engine oil pressure switch that is located on the valve mechanism cover . . . . . 29 kPa ( $(4.27\text{ psi})$ )

Engine oil pressure switch that is located on the cylinder block . . . . . 98 kPa ( $(14.22\text{ psi})$ )

**Note:** There is no automatic shutdown for low coolant level.

**Note:** The capacity of the diode must be 3 amperes with a reverse voltage of 600 volts.

**Note:** The rated current draw of the engine oil pressure switch is 0.42 amperes (5 watts maximum bulb).

**Note:** If necessary, a delay fuse should be used for replacement.

## Charging System Components

### NOTICE

Never operate the alternator without the battery in the circuit. Making or breaking an alternator connection with heavy load on the circuit can cause damage to the regulator.

## Alternator

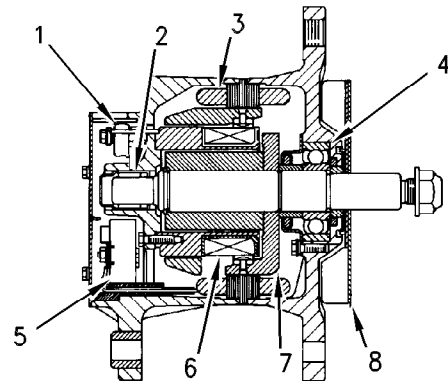

Illustration 30 g00292313

### Alternator

- (1) Regulator
- (2) Roller bearing
- (3) Stator winding
- (4) Ball bearing
- (5) Rectifier bridge
- (6) Field winding
- (7) Rotor assembly
- (8) Fan

The alternator is driven by the crankshaft pulley through a belt. When the engine is running, the pulley rotates the shaft inside the alternator. The rotor assembly is attached to the shaft. The rotor assembly has many magnetic poles. The magnetic poles are similar to fingers. An air space exists between each of the opposite poles. The poles have residual magnetism that produces a small amount of magnet-like lines of force (magnetic field). This magnetic field is produced between the poles. As the rotor assembly begins to turn between the field winding and the stator windings, a small amount of alternating current (AC) is produced in the stator windings. The alternating current is produced from the small magnetic lines of force that are created by the residual magnetism of the poles. The AC is changed into direct current (DC) when the current passes through the diodes of the rectifier bridge. Most of this current provides the battery charge and the supply for the low amperage circuit. The remainder of the current is sent to the field windings. The DC current flow through the field windings (wires around an iron core) increases the strength of the magnetic lines of force. These stronger magnetic lines of force increase the amount of AC that is produced in the stator windings. The increased speed of the rotor assembly also increases the current output of the alternator and the voltage output of the alternator.

## Regulator

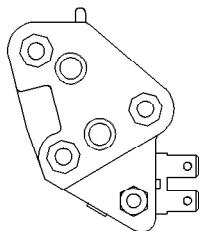

Illustration 31

g00360155

### Typical regulator assembly

The voltage regulator is a solid-state electronic switch. The voltage regulator senses the voltage of the system. The regulator then uses switches to control the current to the field windings. This controls the voltage output in order to meet the electrical demand of the system.

## Starting System Components

### Electric Starting Motor

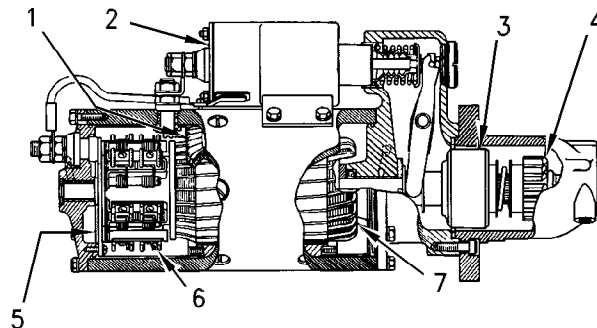

Illustration 32

g00292330

### Starting motor cross section (typical example)

- (1) Field
- (2) Solenoid
- (3) Clutch
- (4) Starter pinion
- (5) Commutator
- (6) Brush assembly
- (7) Armature

The starting motor rotates the engine flywheel at a rate that is fast enough to start the engine.

The starting motor has a solenoid (2). When the start switch is activated, the solenoid (2) will move the starter pinion (4) in order to engage the starter pinion (4) to the ring gear on the engine flywheel. The starter pinion (4) and the ring gear will engage when the circuit between the battery and the starting motor is closed by the electric contacts in the solenoid (2). When the circuit between the battery and the starting motor is complete, the starter pinion (4) will rotate the engine flywheel. A clutch provides protection for the starting motor so that the engine cannot turn the starting motor too fast. When the switch is released, the starter pinion (4) will move away from the ring gear.

## Solenoid

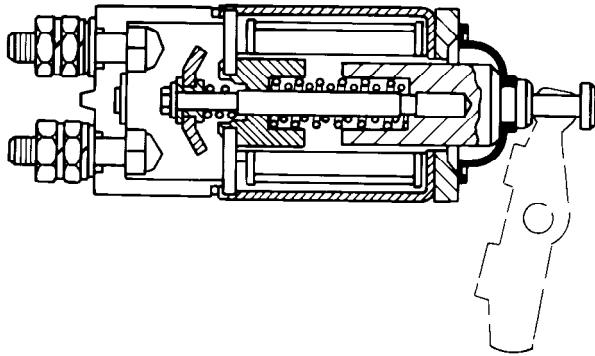

Illustration 33

g00292316

Typical solenoid schematic

A solenoid is an electromagnetic switch that performs two basic functions:

- The solenoid closes the high current starting motor circuit with a low current start switch circuit.
- The solenoid engages the starting motor pinion with the ring gear.

The solenoid has windings (one set or two sets) around a hollow cylinder. A plunger with a spring load device is inside of the cylinder. The plunger can move forward and backward. When the start switch is closed and electricity is sent through the windings, a magnetic field is created. The magnetic field pulls the plunger forward in the cylinder. This moves the shift lever in order for the pinion drive gear to engage with the ring gear. The front end of the plunger then makes contact across the battery and across the motor terminals of the solenoid. The starting motor then begins to turn the flywheel of the engine.

When the start switch is opened, current no longer flows through the windings. The spring now returns the plunger to the original position. At the same time, the spring moves the pinion gear away from the flywheel.

When two sets of windings in the solenoid are used, the windings are called the hold-in winding and the pull-in winding. Both of the windings wind around the cylinder for an equal amount of times. The pull-in winding uses a wire with a larger diameter in order to produce a stronger magnetic field. When the start switch is closed, part of the current flows from the battery through the hold-in winding. The remainder of the current flows through the pull-in windings, to the motor terminal, and then to the ground. When the solenoid is fully activated, the current is shut off through the pull-in windings. Only the smaller hold-in windings are in operation for the extended period of time that is necessary for the engine to be started. The solenoid will now take a smaller amount of current from the battery. Heat that is created by the solenoid will be kept at an acceptable level.

## Other Components

### Circuit Breaker

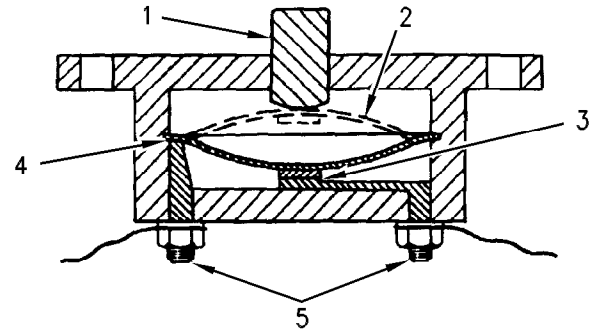

Illustration 34

g00281837

Circuit breaker schematic

- (1) Reset button
- (2) Disc in open position
- (3) Contacts
- (4) Disc
- (5) Battery circuit terminals

The circuit breaker is a switch that opens the battery circuit if the current in the electrical system is higher than the rating of the circuit breaker. The metal disc (2) is activated by heat. As the current in the electrical system increases, the temperature of the metal disc (2) will increase. The heat that is caused by the excessive current will cause a distortion in the metal disc (2). When a distortion occurs in the metal disc (2), the contacts (3) open. A circuit breaker that is open can be reset when the metal disc becomes cooler. Push the reset button (1) in order to close the contacts (3) and reset the circuit breaker.

## Testing And Adjusting Section

### Fuel System

i02182341

#### Fuel System - Inspect

A problem with the components that send fuel to the engine can cause low fuel pressure. This can decrease engine performance.

1. Check the fuel level in the fuel tank. Ensure that the vent in the fuel cap is not filled with dirt.
2. Check all fuel lines for fuel leakage. The fuel lines must be free from restrictions and faulty bends. Verify that the fuel return line is not collapsed.
3. Inspect the fuel filter for excessive contamination. If necessary, install a new fuel filter. Determine the source of the contamination. Make the necessary repairs.
4. Service the primary fuel filter (if equipped).
5. Operate the hand priming pump (if equipped). If excessive resistance is felt, inspect the fuel pressure regulating valve. If uneven resistance is felt, test for air in the fuel. Refer to Testing and Adjusting, "Air in Fuel - Test" for more information.
6. Remove any air that may be in the fuel system. Refer to Testing and Adjusting, "Fuel System - Prime".

i02182932

#### Air in Fuel - Test

This procedure checks for air in the fuel system. This procedure also assists in finding the source of the air.

1. Examine the fuel system for leaks. Ensure that the fuel line fittings are properly tightened. Check the fuel level in the fuel tank. Air can enter the fuel system on the suction side between the fuel priming pump and the fuel tank.

### WARNING

Work carefully around an engine that is running. Engine parts that are hot, or parts that are moving, can cause personal injury.

2. Install a suitable fuel flow tube with a visual sight gauge in the fuel return line. When possible, install the sight gauge in a straight section of the fuel line that is at least 304.8 mm (12 inches) long. Do not install the sight gauge near the following devices that create turbulence:
  - Elbows
  - Relief valves
  - Check valves

Observe the fuel flow during engine cranking. Look for air bubbles in the fuel. If there is no fuel that is present in the sight gauge, prime the fuel system. Refer to Testing and Adjusting, "Fuel System - Prime" for more information. If the engine starts, check for air in the fuel at varying engine speeds. When possible, operate the engine under the conditions which have been suspect.

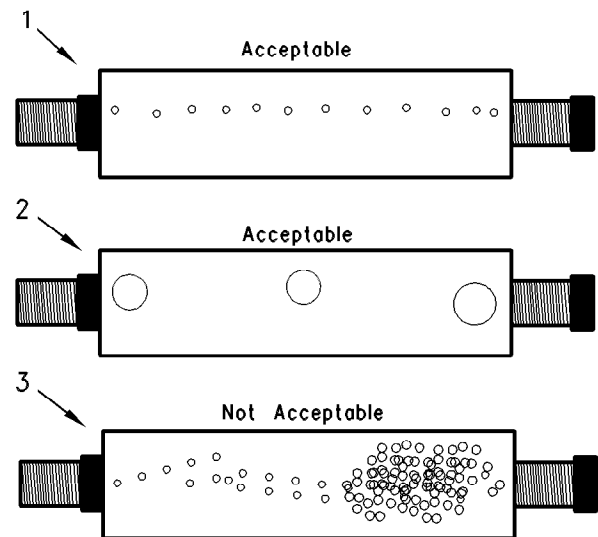

Illustration 35

g00578151

- (1) A steady stream of small bubbles with a diameter of approximately 1.60 mm (0.063 inch) is an acceptable amount of air in the fuel.
- (2) Bubbles with a diameter of approximately 6.35 mm (0.250 inch) are also acceptable if there is two seconds to three seconds intervals between bubbles.
- (3) Excessive air bubbles in the fuel are not acceptable.

3. If excessive air is seen in the sight gauge in the fuel return line, install a second sight gauge at the inlet to the fuel priming pump. If a second sight gauge is not available, move the sight gauge from the fuel return line and install the sight gauge at the inlet to the fuel priming pump. Observe the fuel flow during engine cranking. Look for air bubbles in the fuel. If the engine starts, check for air in the fuel at varying engine speeds.

If excessive air is not seen at the inlet to the fuel priming pump, the air is entering the system after the fuel priming pump. Refer to the Testing and Adjusting, "Fuel System - Prime".

If excessive air is seen at the inlet to the fuel priming pump, air is entering through the suction side of the fuel system.

### WARNING

To avoid personal injury, always wear eye and face protection when using pressurized air.

### NOTICE

To avoid damage, do not use more than 55 kPa (8 psi) to pressurize the fuel tank.

4. Pressurize the fuel tank to 35 kPa (5 psi). Do not use more than 55 kPa (8 psi) in order to avoid damage to the fuel tank. Check for leaks in the fuel lines between the fuel tank and the fuel priming pump. Repair any leaks that are found. Check the fuel pressure in order to ensure that the fuel transfer pump is operating properly. For information about checking the fuel pressure, see Testing and Adjusting, "Fuel System Pressure - Test".
5. If the source of the air is not found, disconnect the supply line from the fuel tank and connect an external fuel supply to the inlet of the fuel priming pump. If this corrects the problem, repair the fuel tank or the stand pipe in the fuel tank.

i02198351

## Finding Top Center Position for No. 1 Piston

This procedure sets the No. 1 piston at the top center position on the compression stroke.

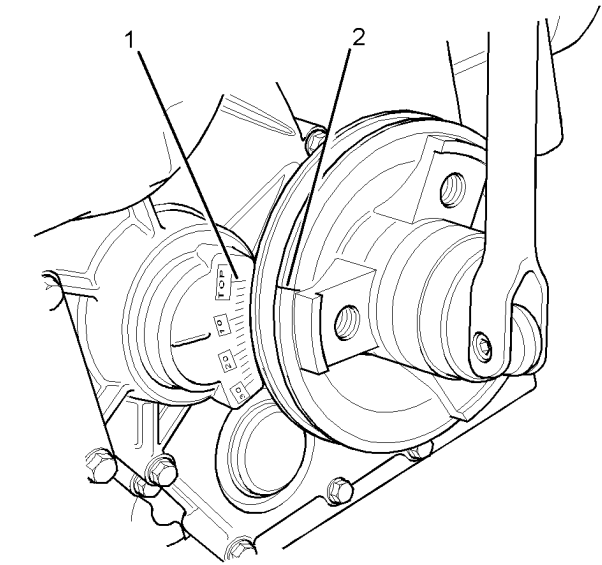

Illustration 36

g01110251

1. Remove the valve mechanism cover. Refer to Disassembly and Assembly, "Valve Mechanism Cover - Remove and Install".
2. Remove the glow plugs. Refer to Disassembly and Assembly, "Glow Plugs - Remove and Install".
3. Rotate the engine crankshaft until the exhaust valve for No. 1 cylinder is nearly closed and the inlet valve for No. 1 cylinder is starting to open. Rotate the crankshaft through approximately 360 degrees and align the timing mark (2) on the crankshaft pulley with the "TOP" mark (1) on the timing case.
4. Install the glow plugs. Refer to Disassembly and Assembly, "Glow Plugs - Remove and Install".
5. Install the valve mechanism cover. Refer to Disassembly and Assembly, "Valve Mechanism Cover - Remove and Install".

i08144816

## Fuel Injection Timing - Check

Fuel injection timing is set in the factory. Fuel injection timing cannot change during operation.

**Note:** If a fuel injection pump is removed, replace the old shims with new shims of the same thickness. Old shims should not be used.

**Note:** If the thickness of the shim is 0.5 mm (0.0197 inch), or the thickness of the shim is below 0.5 mm (0.0197 inch), install beaded shims. If the shim thickness is above 0.5 mm (0.0197 inch), install the non-beaded shim. Then install the beaded shim. Ensure that the beading on the beaded shim faces upward, toward the bottom of the fuel injection pump.

On 403J-15, 403J-17 and 403J-17T engines, select the correct combination of shims from table 1 .

Table 1

Shim Thickness (mm)	Part Number	Beaded
0.2	131437541	Yes
0.3	131437551	Yes
0.4	131437561	Yes
0.5	131437571	Yes
0.5	131437580	No

On 403J-07, 403J-11, and 403J-11T engines, select the correct combination of shims from table 2 .

Table 2

Shim Thickness (mm)	Part Number	Beaded
0.2	131437590	Yes
0.3	131437600	Yes
0.4	131437610	Yes
0.5	131437620	Yes
0.5	131437630	No

On 402J-05 engines, select the correct combination of shims from table 3 .

Table 3

Shim Thickness (mm)	Part Number	Beaded
0.2	131437381	Yes
0.3	131437391	Yes
0.4	131437401	Yes
0.5	131437411	Yes
0.5	131437470	No

If the original shim thickness cannot be determined, contact the Dealer Solution Network. The user must provide the full engine number of the product that is serviced.

i02183588

## Fuel Injector - Test

Perform the following procedures in order to determine if a fuel injector does not work correctly.

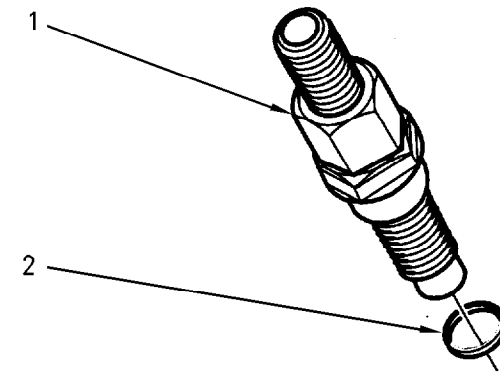

Illustration 37

g00846800

- (1) Fuel injector  
(2) Sealing washer

1. Run the engine at low idle.
2. Loosen the nut for the fuel supply line at each fuel injector (1). Listen for the low idle to decrease or become rough when the nuts are loosened at each cylinder.

The fuel injector may be faulty if the following items occur during the test:

- Engine rpm does not decrease.
- The engine continues to run properly.

3. If the fuel injector is worn or damaged, remove the fuel injector for additional testing.

**Note:** If leakage at the nut for the fuel supply line occurs, make sure that the fuel supply line and the nut for the fuel supply line are correctly aligned with the inlet connection of the fuel injector. Do not tighten the nut for the fuel supply line on the high pressure fuel line more than the recommended torque. If the nut is tightened more, the fuel line may become restricted or the threads of the fuel injector and the nut may be damaged.

## Inspection and Cleaning of the Fuel Injectors

Before a fuel injector is tested, remove any loose carbon from the tip of the nozzle. Do not use abrasive material or a wire brush in order to clean the nozzle.

**Note:** Extra care should be used in handling the fuel injector in order to prevent damage to the nozzle tip. A scratch or a burr could cause needle leakage or spray distortion. Dirt in the orifices of the nozzle tip can damage engine components. The dirt can also distort the spray pattern of the nozzle.

## Leakage Test

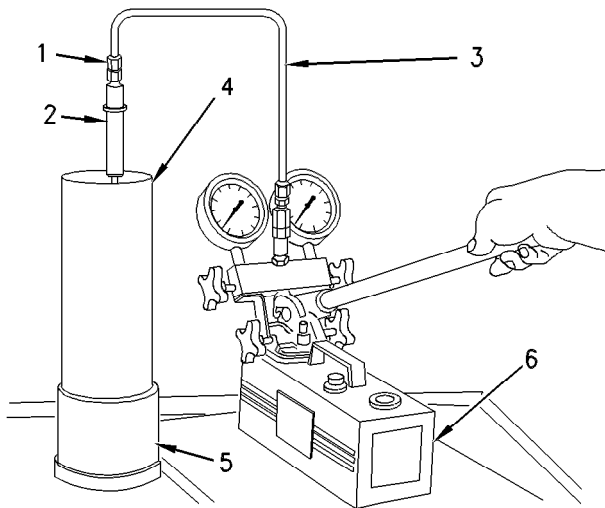

Illustration 38

g00470020

- (1) Adapter
- (2) Fuel injector
- (3) Tube Assembly
- (4) Extension
- (5) Fuel Collector
- (6) Filter

This procedure tests for leakage around all components of the fuel injector.

1. Connect the fuel injector (2) to suitable tooling that is similar to the Illustration 38 .

Position fuel injector (2) so that the direction of the fuel spray is into the extension (4) and the fuel collector (5).

2. Pump the pressure to about 2030 kPa (294 psi) below the opening pressure of the fuel injector (2).

Refer to Specifications, "Fuel Injectors" for the correct setting of the opening pressure.

Release the handle. When the pressure begins to decrease, note the time that is required for the pressure to decrease to approximately 0 kPa (0 psi). If the fuel injector (2) is not faulty, the time will not be less than 5 seconds or more than 45 seconds.

If the time that is required for the pressure to decrease to 0 kPa (0 psi) is less than 5 seconds, too much fuel is leaking around the valve needle. Replace fuel injector (2).

3. Look for any leakage in the connection from the adapter to the fuel injector (2). If leakage is visible, make sure that the components are tightened to the correct torque.

If leakage continues to occur, unscrew the body of the fuel injector (2) from the nozzle nut. Inspect the threaded surfaces for foreign particles and damage.

If the faces are damaged, replace the fuel injector (2).

If the faces are undamaged, clean the faces. Repeat Steps 1 and 2. If leakage continues to occur, replace the fuel injector.

4. Pump the pressure of the injector tester to approximately 2030 kPa (294 psi) below the opening pressure of fuel injector (2). Fuel should not collect on the tip of the fuel injector (2) in a sufficient quantity in order to drip from the tip for at least ten seconds. A light dampness is acceptable.

If the results of the tests are not acceptable, replace the fuel injector (2).

## Pressure Test

### WARNING

Ensure that you wear eye protection at all times during testing. When fuel injectors are tested, test fluids travel through the orifices of the nozzle tip with high pressure. Under this amount of pressure, the test fluid can pierce the skin and cause serious injury to the operator. Always keep the tip of the fuel injector pointed away from the operator and into the fuel collector and extension.

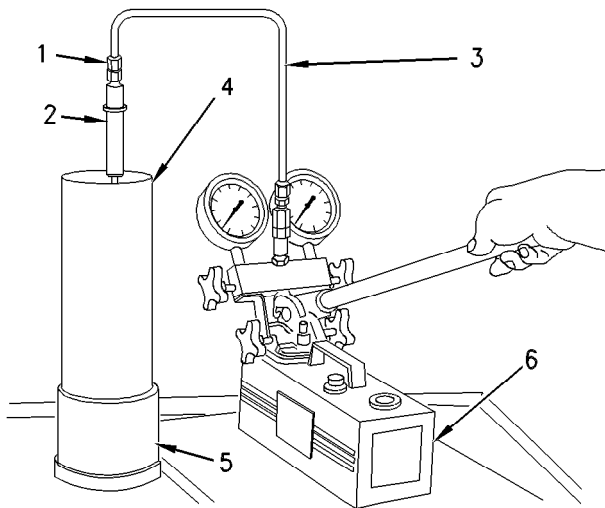

Illustration 39

g00470020

- (1) Adapter
- (2) Fuel injector
- (3) Tube Assembly
- (4) Extension
- (5) Fuel Collector
- (6) Filter

#### NOTICE

Do not use dirty test fluids when you test fuel injectors. Also, do not test fuel injectors unless you have the correct service tools. The use of dirty test fluids and the use of incorrect service tools will result in damage to the fuel injectors.

**Note:** This procedure is a test of the opening pressure of the fuel injector.

1. Connect the fuel injector (2) to suitable tooling that is similar to the Illustration 39 .

The spray from the fuel injector (2) must be directed into the extension (4) and the fuel collector (5).

Use clean calibration fluid when the fuel injectors are tested. The calibration fluid should be equivalent to SAE J-967 (ISO 4113) oil.

2. Close the gauge protector valve. Close the shutoff valve. Open the pump isolator valve. Flush the fuel injector (2) by operating the nozzle tester. Operate the nozzle tester for 10 to 15 strokes at a rate of approximately sixty strokes per minute.

3. Open the gauge protector valve. Slowly increase the pressure until the valve in the fuel injector (2) opens. Note the highest pressure indication on the dial indicator before the pointer moves to 0 kPa (0 psi). This highest pressure indication is the opening pressure of fuel injector (2). The opening pressure occurs when the valve needle is lifted from the nozzle seat.

Refer to Specifications, "Fuel Injection Nozzles" for the correct pressure settings. If the opening pressure is not within the range of the setting which is given in the table, the fuel injector (2) must be replaced.

### Test for the Nozzle Spray Pattern

#### **WARNING**

Ensure that you wear eye protection at all times during testing. When fuel injectors are tested, test fluids travel through the orifices of the nozzle tip with high pressure. Under this amount of pressure, the test fluid can pierce the skin and cause serious injury to the operator. Always keep the tip of the fuel injector pointed away from the operator and into the fuel collector and extension.

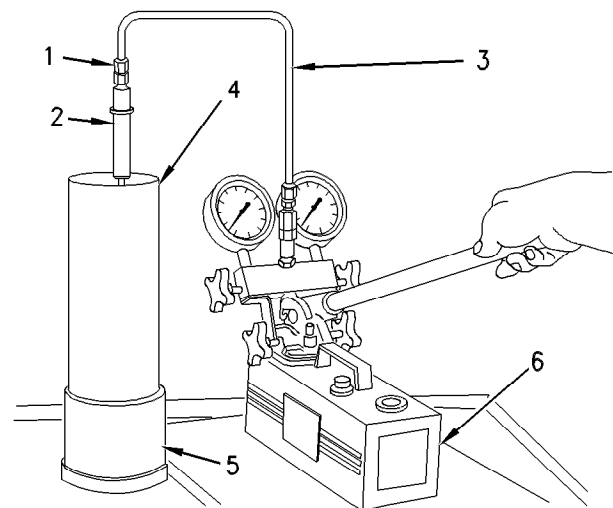

Illustration 40

g00470020

- (1) Adapter
- (2) Fuel injector
- (3) Tube Assembly
- (4) Extension
- (5) Fuel Collector
- (6) Filter

The pressure adjustment must be correct before you test the spray pattern.

This procedure tests for the correct spray pattern for the fuel injectors.

1. Connect the fuel injector (2) to suitable tooling that is similar to the Illustration 40 .

Position the fuel injector (2) so that the direction of the fuel spray is into the extension (4) and the fuel collector (5).

2. Close the gauge protector valve and the shutoff valve. Open the pump isolator valve.

**Note:** Be sure that the gauge protector valve is closed before the fuel injector (2) is removed from the nozzle tester. Closing the valve will prevent damage to the pressure gauge.

i01944302

## Fuel Quality - Test

Use the following procedure to test for problems regarding fuel quality:

1. Determine if water and/or contaminants are present in the fuel. Check the water separator (if equipped). If a water separator is not present, proceed to Step 2. Drain the water separator, if necessary. A full fuel tank minimizes the potential for overnight condensation.

**Note:** A water separator can appear to be full of fuel when the water separator is actually full of water.

2. Determine if contaminants are present in the fuel. Remove a sample of fuel from the bottom of the fuel tank. Visually inspect the fuel sample for contaminants. The color of the fuel is not necessarily an indication of fuel quality. However, fuel that is black, brown, and/or similar to sludge can be an indication of the growth of bacteria or oil contamination. In cold temperatures, cloudy fuel indicates that the fuel may not be suitable for the operating conditions. Refer to Operation and Maintenance Manual, "Fuel Recommendations" for more information.
3. If fuel quality is still suspected as a possible cause of problems regarding engine performance, disconnect the fuel inlet line, and temporarily operate the engine from a separate source of fuel that is known to be good. This will determine if the problem is caused by fuel quality. If fuel quality is determined to be the problem, drain the fuel system and replace the fuel filters. Engine performance can be affected by the following characteristics:
  - Cetane number of the fuel
  - Air in the fuel

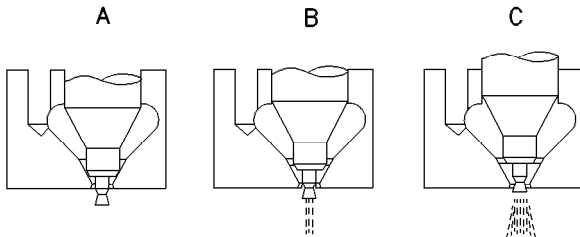

Illustration 41

g00468241

Phases of operation and spray pattern of the fuel injector

The spray angle is 4 degrees from the vertical when the nozzle is fully open.

- (A) Closed nozzle  
(B) Open nozzle  
(C) Fully open nozzle

3. Quickly pump the nozzle tester and look at the spray pattern when the fluid begins to flow through the orifices of fuel injector (2) .

The spray flows around the tip of the nozzle. A difference in the nozzle spray patterns indicates that the fuel injector (2) is faulty. Refer to the correct spray pattern in Illustration 41 .

Observe the following characteristics of the spray:

- Drops of fuel should not be in the spray.
- Fuel should be sprayed in the shape of a cone around the nozzle.
- Fuel should be sprayed evenly in a 360 degree pattern around the nozzle.

- Other fuel characteristics

i08155890

## Fuel System - Prime

### NOTICE

Care must be taken to ensure that fluids are contained during performance of inspection, maintenance, testing, adjusting and repair of the product. Be prepared to collect the fluid with suitable containers before opening any compartment or disassembling any component containing fluids.

Dispose of all fluids according to local regulations and mandates.

Use the following procedure to prime the fuel system:

If air enters the fuel system, the air must be purged from the fuel system before the engine can be started. Air can enter the fuel system when the following events occur:

- The fuel tank is empty or the fuel tank has been partially drained.
- The low-pressure fuel lines are disconnected.
- A leak exists in the low-pressure fuel system.
- The fuel filter is replaced.

## Mechanical Fuel Priming Pump

### Primary Filter

Ensure that the air is removed from the primary filter before you prime the fuel filter. Refer to illustration 42

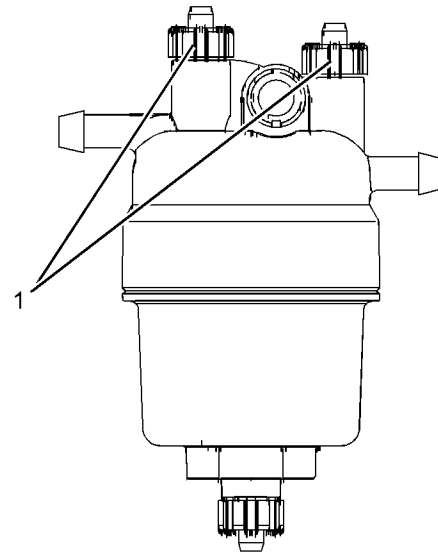

Illustration 42

g01316878

This filter may not be installed on the engine.

(1) Vent screws

## Priming the Primary Fuel Filter

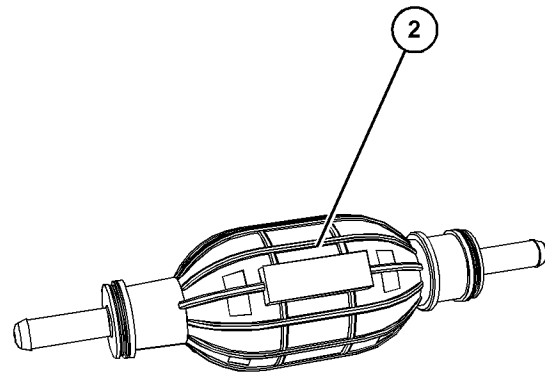

Illustration 43

g06221845

Typical example

1. If equipped, operate the hand priming pump (2) until fuel free from air comes from the vent screw (1). Then close vent screw (1) by hand.

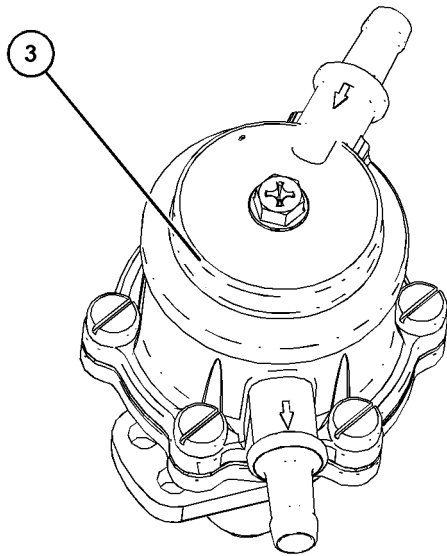

Illustration 44 g06221885  
Typical example

2. If the hand priming pump is not installed, operate the starting motor to crank the engine. Crank the engine to operate the transfer pump (3). Do not operate the transfer pump for more than 15 seconds. After 15 seconds, stop and wait 30 seconds before operating the starting motor.
3. When fuel free from air comes from the vent screw (1) close vent screw (1) by hand.

### Secondary Fuel filters

There are three types of fuel filter that may be installed on the engine.

- Element
- Canister
- Spin-on filter with fuel priming pump

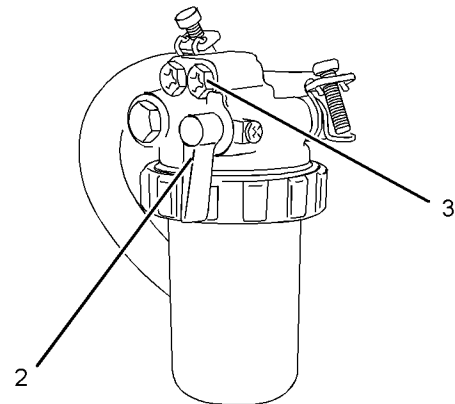

Illustration 45 g01327360  
Typical example of an element filter  
(2) Fuel valve  
(3) Vent screw

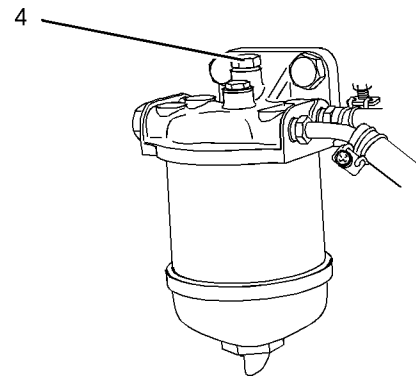

Illustration 46 g01327361  
Typical example of a canister  
(4) Vent screw

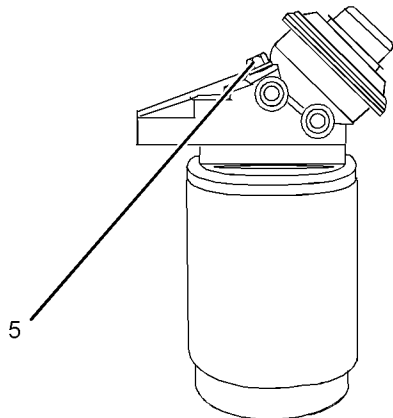

Illustration 47

g01327363

Typical example of a spin-on filter with fuel priming pump

(5) Vent screw

Vent screw (3) is installed on the filter that has an element. Vent screw (4) is installed on the fuel filter that has a canister. Vent screw (5) is installed on the spin-on filter.

## Priming the System

**Note:** Some fuel system will use gravity to prime the primary fuel filter. When gravity is used to deliver the fuel, ensure that the fuel tank is full and that all stop valves in the fuel line are open.

There are four different types of systems that can be installed on the engine to prime the fuel system. Refer to illustration 48 .

- Hand priming pump
- In-line hand priming pump
- Electrical priming pump
- Transfer pump that is operated by the starting motor

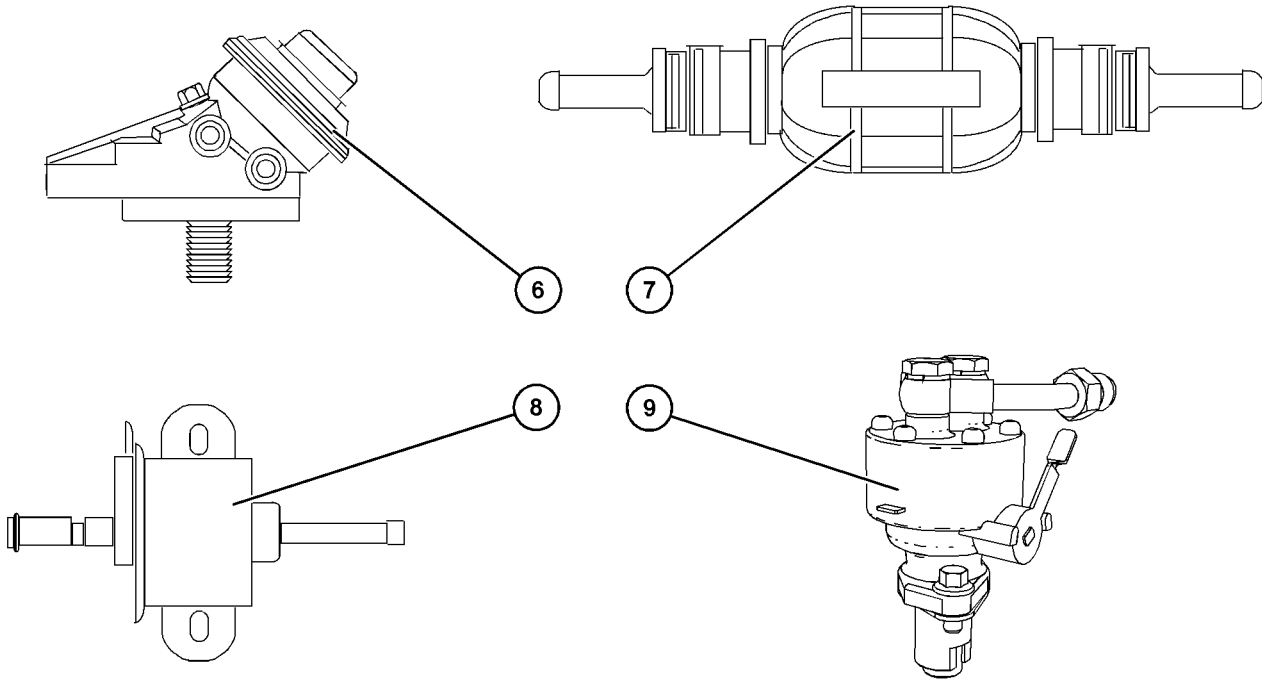

Illustration 48

g06523817

Typical example

- (6) Hand priming pump
- (7) In-line priming pump

- (8) Electrical priming pump
- (9) Fuel transfer pump with hand priming

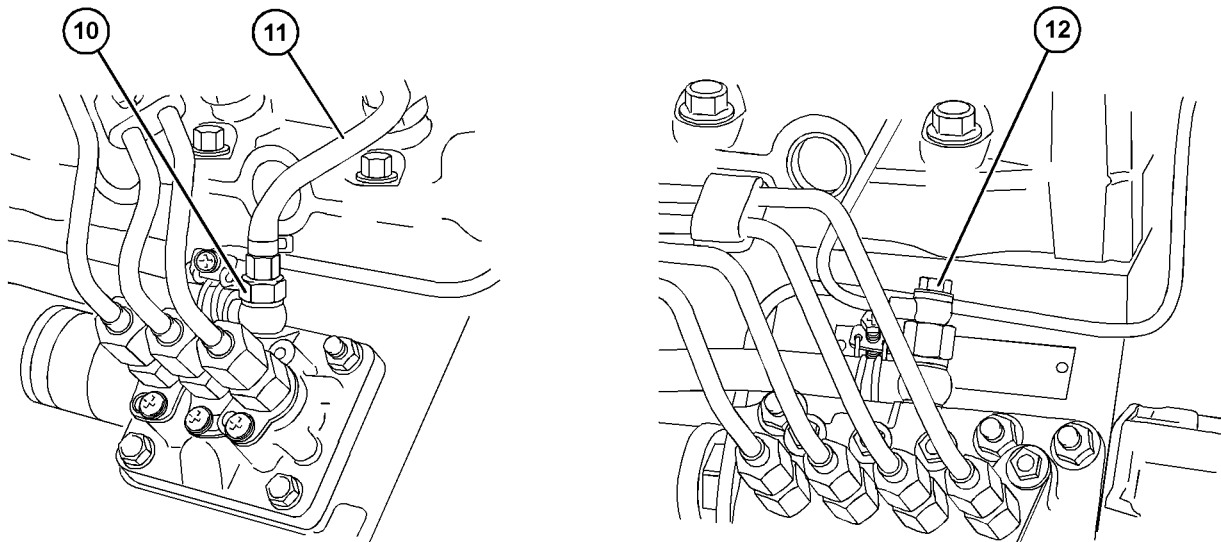

Illustration 49

g06523835

- (10) Connector bolt

- (11) Fuel return line

- (12) Connector bolt

## Hand Priming Pump 6

To identify the hand priming pump, refer to illustration 48 .

1. Ensure that fuel valve (2) for the fuel filter that has an element is in the ON position. Refer to illustration 45 .
2. Loosen vent screw (3), (4), or (5) on the fuel filter.
3. Operate hand priming pump (6). When fuel free from air flows from the vent screw tighten the vent screw.
4. Loosen connection (10) or (12) at the fuel injection pump. Refer to illustration 49 .

**Note:** Fuel return line (11) may need to be removed to prime the fuel system.

5. Operate the hand priming pump. When fuel free from air flows from the connections tighten the connecting bolt.
6. The engine should now be able to start. Operate the starting motor to start the engine.

**Note:** Do not operate the starting motor for more than 15 seconds. If the engine does not start after 15 seconds, stop and wait for 30 seconds before trying again.

## In-line Priming Pump 7

To identify the in-line priming pump, refer to illustration 48 .

1. Ensure that fuel valve (2) for the fuel filter that has an element is in the ON position. Refer to illustration 45 .
2. Loosen vent screw (3), (4), or (5) on the fuel filter.
3. Operate in-line priming pump (7). When fuel free from air flows from the vent screw tighten the vent screw.
4. Loosen connection (10) or (12) at the fuel injection pump. Refer to illustration 49 .

**Note:** Fuel return line (11) may need to be removed to prime the fuel system.

5. Operate the in-line priming pump. When fuel free from air flows from the connections tighten the connecting bolt.
6. The engine should now be able to start. Operate the starting motor to start the engine.

**Note:** Do not operate the starting motor for more than 15 seconds. If the engine does not start after 15 seconds, stop and wait for 30 seconds before trying again.

## Electrical Priming Pump 8

To identify the electrical priming pump, refer to illustration 48 .

Turn the keyswitch to the ON position for 2 minutes to prime the fuel system. Turn keyswitch to OFF position, then turn on again. The engine is primed and ready to start.

If the engine fails to start, follow Step 1 through Step 6.

1. Ensure that fuel valve (2) for the fuel filter that has an element is in the ON position. Refer to illustration 45 .
2. Loosen vent screw (3), (4), or (5) on the fuel filter.
3. Operate electrical priming pump (8). When fuel free from air flows from the vent screw tighten the vent screw. Switch off the electrical priming pump.
4. Loosen connection (10) or (12) at the fuel injection pump. Refer to illustration 49 .

**Note:** Fuel return line (11) may need to be removed to prime the fuel system.

5. Operate the in-line priming pump. When fuel free from air flows from the connections tighten the connecting bolt.
6. The engine should now be able to start. Operate the starting motor to start the engine.

**Note:** Do not operate the starting motor for more than 15 seconds. If the engine does not start after 15 seconds, stop and wait for 30 seconds before trying again.

## Fuel Transfer Pump 9

To identify the fuel transfer pump, refer to illustration 48 .

**Note:** If the transfer pump is not equipped with a manual priming lever and the engine is not equipped with any other priming option, you must operate the starting motor to prime the fuel system. Do not operate the starting motor for more than 15 seconds continuously. After 15 seconds, stop and wait for 30 seconds before operating the starting motor again.

1. Ensure that fuel valve (2) for the fuel filter that has an element is in the ON position. Refer to illustration 45 .
2. Loosen vent screw (3), (4), or (5) on the fuel filter.

3. Operate fuel transfer pump (9). When fuel free from air flows from the vent screw tighten the vent screw. Stop the fuel transfer pump.
4. Loosen connection (10) or (12) at the fuel injection pump. Refer to illustration 49 .

**Note:** Fuel return line (11) may need to be removed to prime the fuel system.

5. Operate the fuel transfer pump. When fuel free from air flows from the connections tighten the connecting bolt. Stop the transfer pump.
6. The engine should now be able to start. Operate the starting motor to start the engine.

**Note:** Do not operate the starting motor for more than 15 seconds. If the engine does not start after 15 seconds, stop and wait for 30 seconds before trying again.

i02617170

## Gear Group (Front) - Time

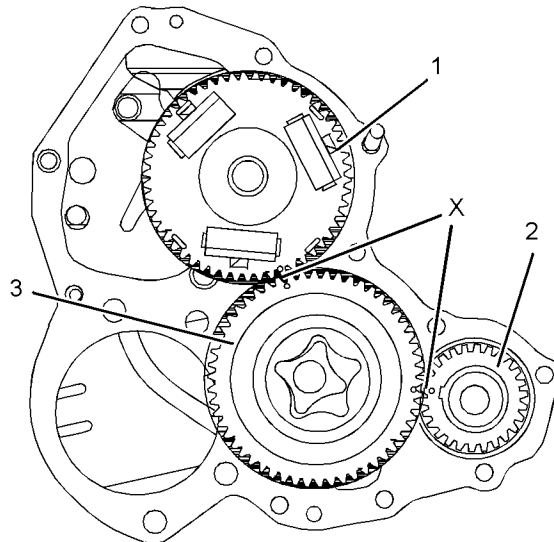

Illustration 50

g01335186

1. Align timing mark (X) on idler gear (3) with the timing mark on crankshaft gear (2) and align timing mark (X) on idler gear (3) with the timing mark on camshaft gear (1).

i03011727

## Governor - Adjust

**Note:** The setting of the front housing is only necessary if the front housing is damaged or if the front housing must be renewed.

Table 4

Required Tools			
Tool	Part Number	Part Description	Qty
A	21825617	Dial Indicator graduated in 0.01 mm (0.0004 inch)	1

(continued)

(Table 4, contd)

	-	Extension that is 20 mm (0.787 inch) long	1
B	27610331	Dial holder	1
C	27610332	Adapter for the cylinder block	1
D	27610333	Calibration spring	1
E	-	Allen head screw (M4 x 20 mm x 0.70)	1
F	-	Optical Tachometer	1

## Record the Governor Settings

### NOTICE

The engine must be in running condition in order to carry out the governor adjustment procedure. If the engine cannot be returned to a running condition contact an authorized Perkins distributor

### NOTICE

If the engine is fitted with a Boost Compensation Device contact an authorized Perkins distributor.

If the front housing has been removed, install the front housing. Refer to Disassembly and Assembly, "Housing (Front) - Install"

The setting of the low idle stop screw and the high idle stop screw must be recorded. The settings are recorded in order to ensure that the governor operation is restored.

**Note:** Engine speed must be recorded from the crankshaft.

1. Operate the engine until the normal operating temperature is reached.
2. Use Tooling (F) to record the engine rpm at low idle.
3. Accelerate the engine to high idle. Use Tooling (F) and record the engine rpm as "Speed A" .

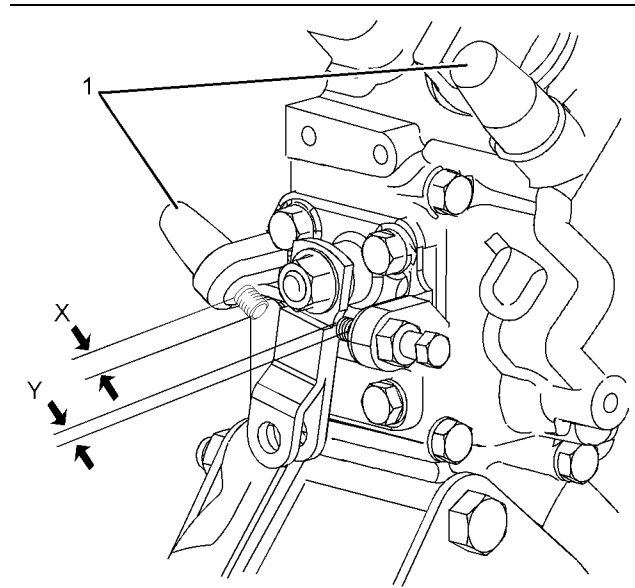

Illustration 51

g01494533

Typical example

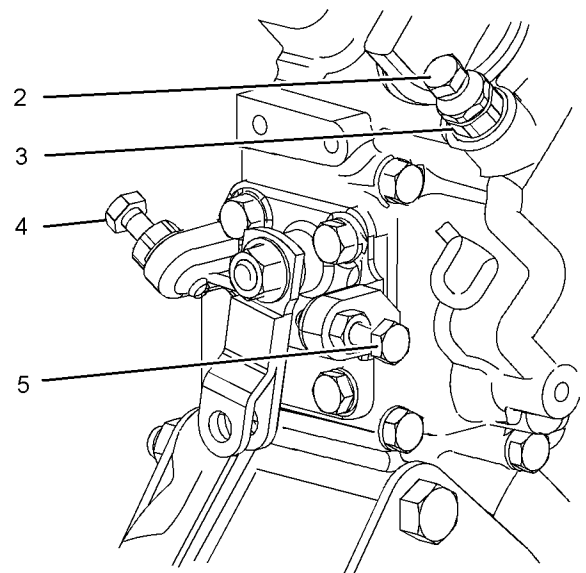

Illustration 52

g01445067

4. Remove tamper proof caps (1).
5. Record Protrusion (X) of the high idle stop screw (4).
6. Record Protrusion (Y) of the low idle stop screw (5).
7. Release locknut (3). Turn high idle trimmer screw (2) for four turns counterclockwise and tighten locknut (3).
8. Accelerate the engine to high idle. Use Tooling (F) and record the engine rpm as "Speed B" .

**Note:** The recorded "Speed B" will be lower than the recorded "Speed A" .

## Removal of the Old Front Housing

1.

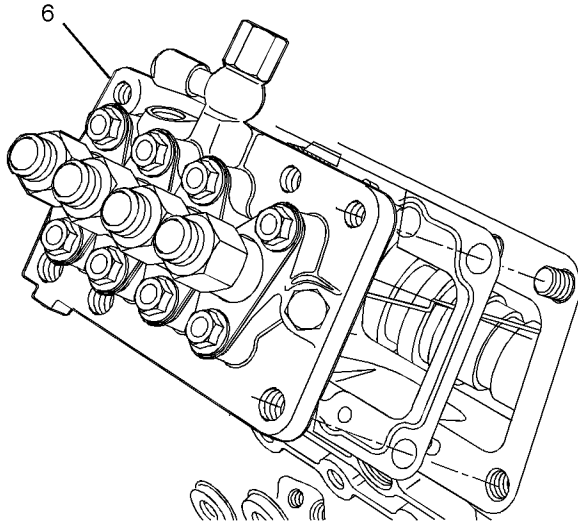

Illustration 53

g01490633

1. Remove fuel injection pump (6). Refer to Disassembly and Assembly, "Fuel Injection Pump - Remove and Install" for the correct procedure.
2. Remove the crankshaft pulley. Refer to Disassembly and Assembly, "Crankshaft Pulley - Remove"

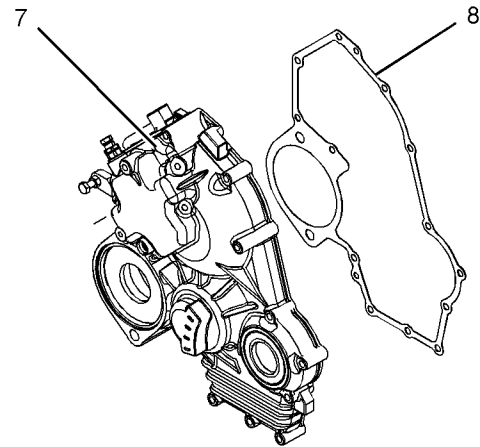

Illustration 54

g01490998

3. Remove front housing (7). Refer to Disassembly and Assembly, "Housing (Front) - Remove" for the correct procedure.
4. Remove the gasket (8). Ensure that the face of the front plate is clean.

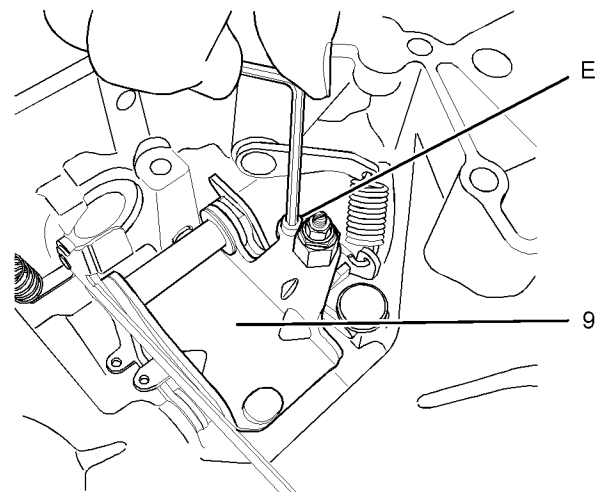

Illustration 55

g01494273

5. Install Tooling (E) to lever assembly (9). Tighten tooling (E) to a torque of 0.4 N·m (3.540 lb in).

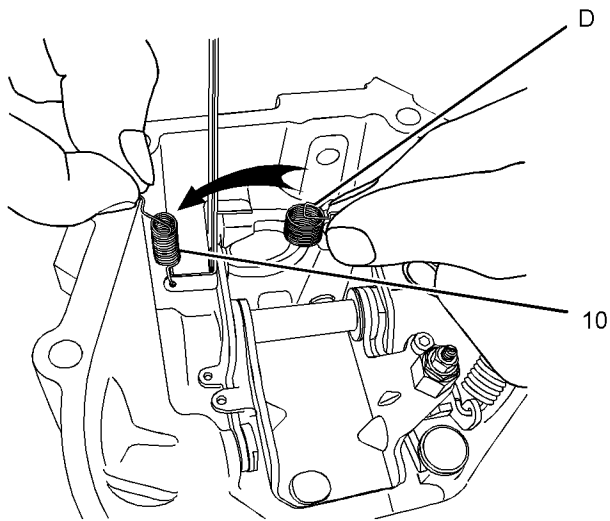

Illustration 56 g01494293

6. Remove start spring (10) and replace the start spring with Tooling (D).
7. Install the front housing. Refer to Disassembly and Assembly, "Housing (Front) - Install" for the correct procedure.

**Note:** Do not install a gasket.

8. Install the fuel injection pump to the cylinder block. Install the original shim. Refer to Disassembly and Assembly, "Fuel Injection Pump - Remove and Install" for the correct procedure.

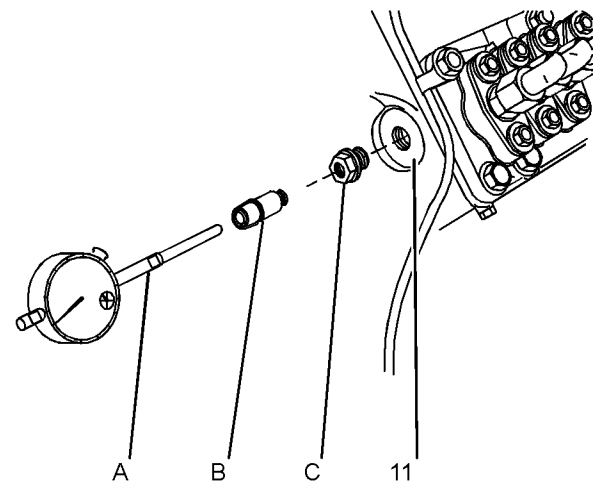

Illustration 57 g01494333

9. Install Tooling (C) into cylinder block (11).
10. Install Tooling (B) into Tooling (C).
11. Assemble Tooling (A).
12. Install Tooling (A) into Tooling (B) until the extension on Tooling (A) touches the rack of the fuel injection pump.

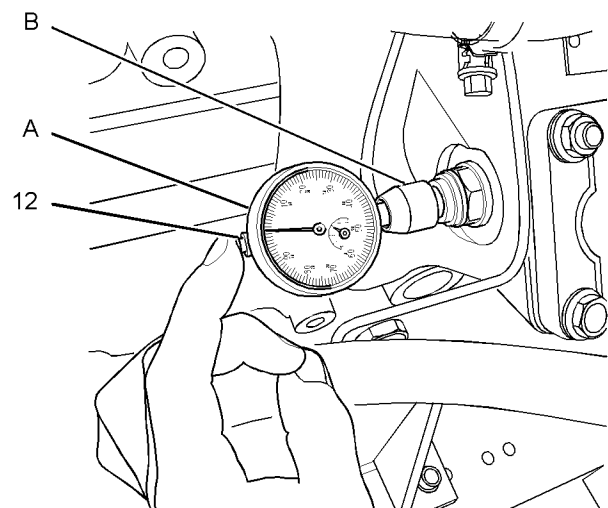

Illustration 58 g01446121

13. Push Tooling (A) into Tooling (B) for a further 2 mm (0.0787 inch). Lock Tooling (B) in order to retain Tooling (A) in position. Set Tooling (A) to read  $2.00 \pm 0.01$  mm ( $0.0787 \pm 0.0004$  inch).

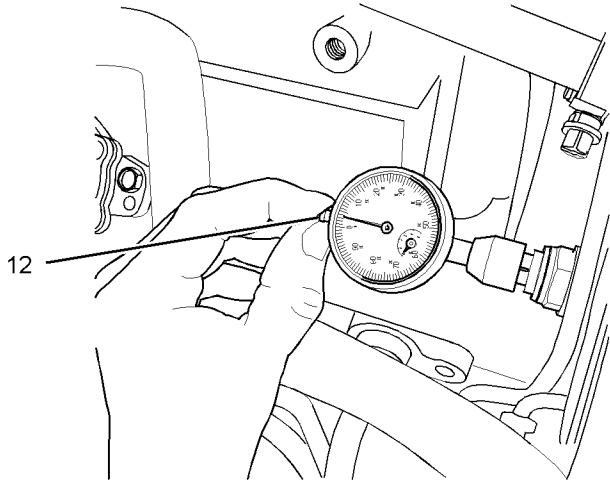

Illustration 59

g01446123

14. Push plunger (12) of Tooling (A) several times in order to seat the rack of the fuel injection pump. When the plunger is gently released, check that Tooling (A) reads  $2.00 \pm 0.01$  mm ( $0.0787 \pm 0.0004$  inch).

**Note:** If the rack of the fuel injection pump has heavy resistance to movement, remove tooling (A). Remove the fuel injection pump. Wash the fuel injection pump with a suitable cleaner. Install the fuel injection pump. Repeat steps 12, 13 and 14.

## Setting the New Front Housing

**Note:** Do not move the position of Tooling (A), Tooling (B) or Tooling (C) in the cylinder block.

1. Pull plunger (12) of Tooling (A) until the plunger has reached the fully out position. Use a suitable clip to retain the plunger in this position.
2. Remove the fuel injection pump. Refer to Disassembly and Assembly, "Fuel Injection Pump - Remove and Install" for the correct procedure.
3. Remove the original front housing. Refer to Disassembly and Assembly, "Housing (Front) - Remove" for the correct procedure.
4. Disassemble the original front housing. Refer to Disassembly and Assembly, "Housing (Front) - Disassemble" for the correct procedure.

5. Assemble the replacement front housing with the parts that were removed from the original front housing. Install a new fuel screw and a new locknut. Refer to Disassembly and Assembly, "Housing (Front) - Assemble" for the correct procedure.
6. Remove Tooling (E) from the original front housing. Install Tooling (E) to the lever assembly of the replacement front housing. Tighten Tooling (E) to a torque of  $0.4$  N·m ( $3.5$  lb in).
7. Remove Tooling (D) from the original front housing. Install Tooling (D) into the replacement front housing.
8. Install the replacement front housing. Refer to Disassembly and Assembly, "Housing (Front) - Install" for the correct procedure.

**Note:** Do not install a gasket.

9. Install the fuel injection pump to the cylinder block. Install the original shim. Refer to Disassembly and Assembly, "Fuel Injection Pump - Remove and Install" for the correct procedure.
10. Remove the clip from plunger (12) of Tooling (A).

## Setting the Fuel Screw

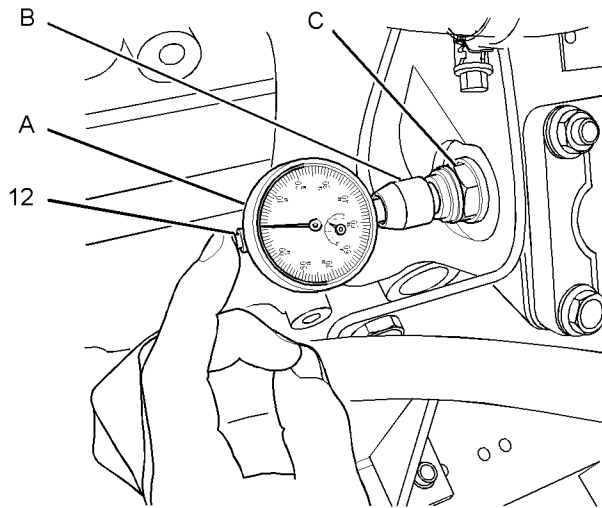

Illustration 60

g01494853

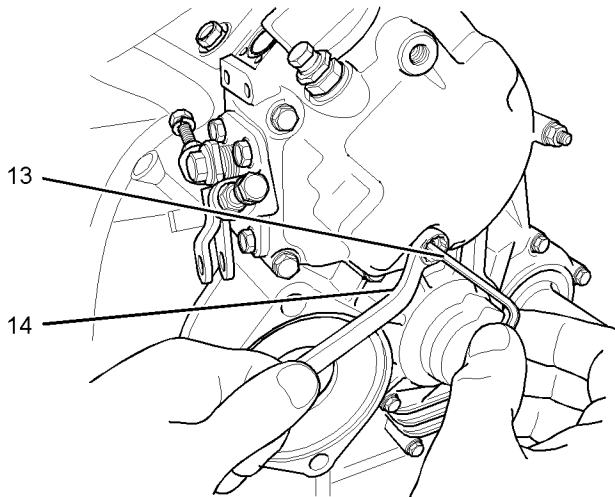

Illustration 61

g01446186

1. Release the plunger on Tooling (A). Do not move the position of Tooling (A), Tooling (B) or Tooling (C) in the cylinder block.
2. Use a ring spanner (Box wrench) (14) to retain the locknut of the fuel screw in position.
3. Use an allen wrench (13) to rotate the allen head screw. Observe the reading on the dial indicator. Adjust the allen head screw until the indicator reads  $2.00 \pm 0.01$  mm ( $0.0787 \pm 0.0004$  inch).

4. Tighten the locknut to a torque of 6 N·m (55 lb in) in order to retain the allen head screw in position. The fuel screw is now set.
5. Ensure that the reading of Tooling (A) is  $2.00 \pm 0.01$  mm ( $0.0787 \pm 0.0004$  inch).

## Final Installation of the New Front Housing

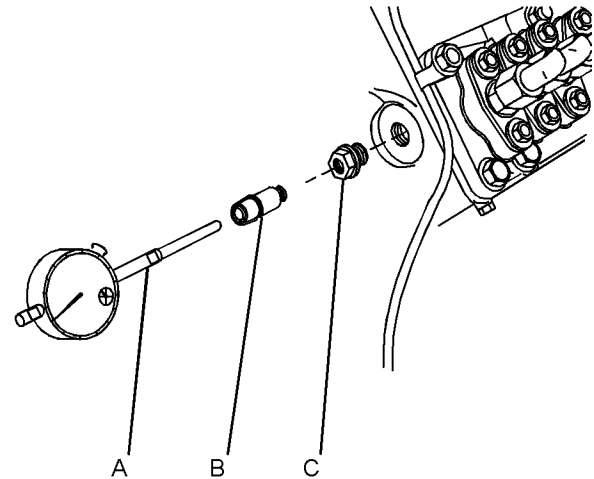

Illustration 62

g01495413

1. Remove Tooling (A) and Tooling (B).
2. Remove Tooling (C).
3. Remove the fuel injection pump. Refer to Disassembly and Assembly, "Fuel Injection Pump - Remove and Install" for the correct procedure.
4. Remove the front housing. Refer to Disassembly and Assembly, "Housing (Front) - Remove" for the correct procedure.

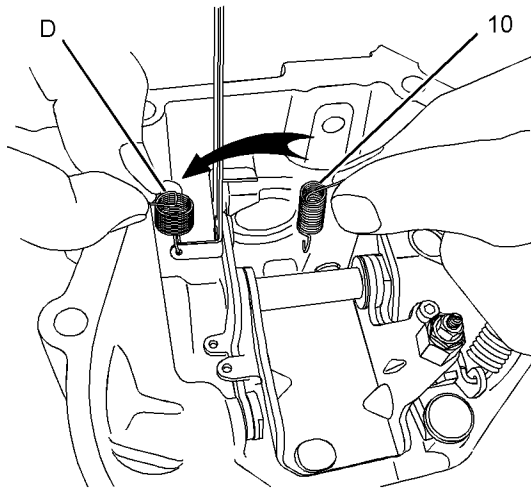

Illustration 63 g01494353

5. Remove Tooling (D). Install original start spring (10).

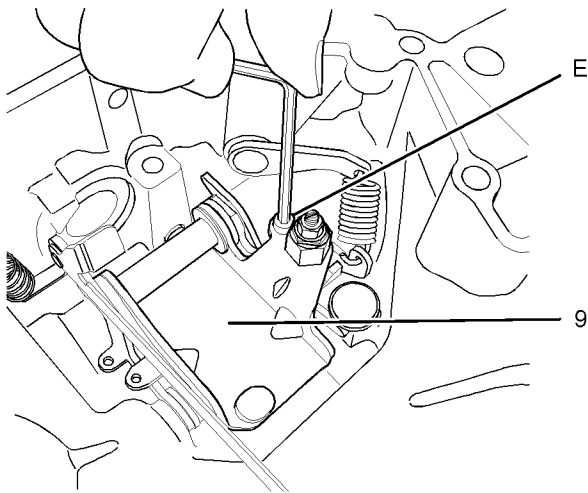

Illustration 64 g01494273

6. Remove Tooling (E) from lever assembly (9).

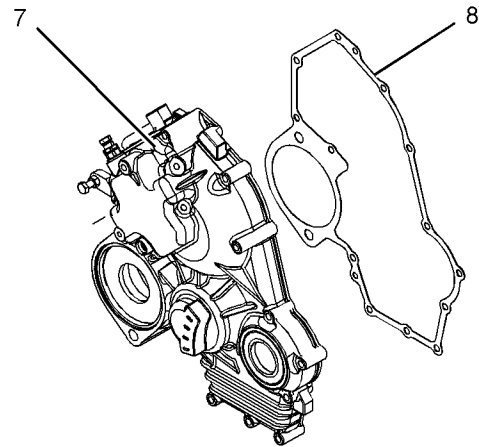

Illustration 65 g01490998

7. Install a new gasket (8). Ensure that the gasket is clean and free from damage.  
8. Install the replacement front housing (7) Refer to Disassembly and Assembly, "Housing (Front) - Install" for the correct procedure.

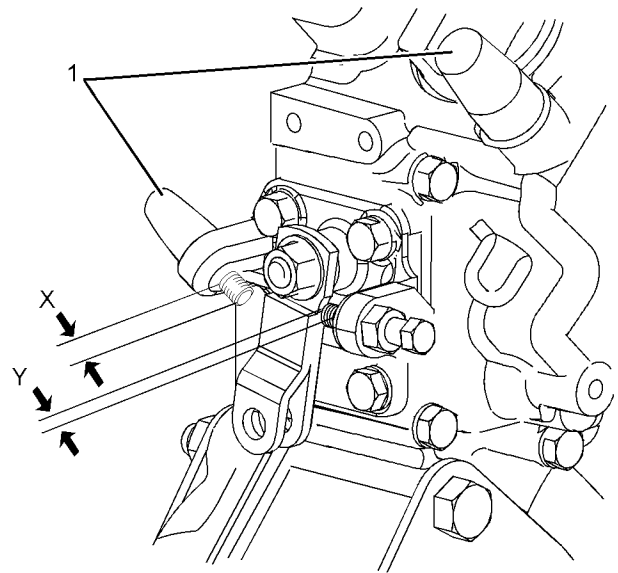

Illustration 66 g01494533  
Typical example

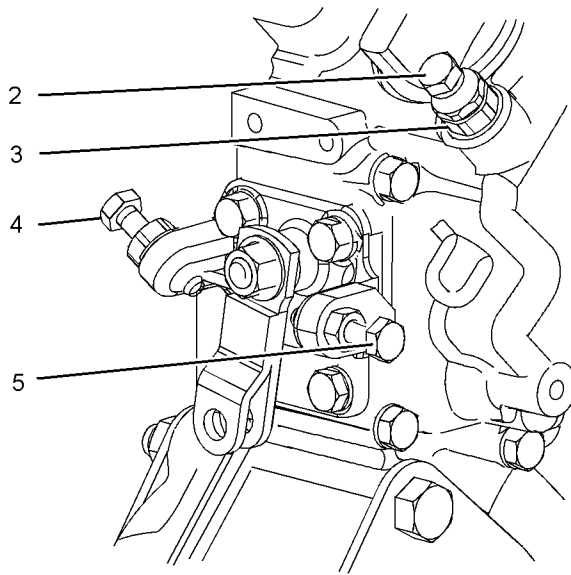

Illustration 67

g01445067

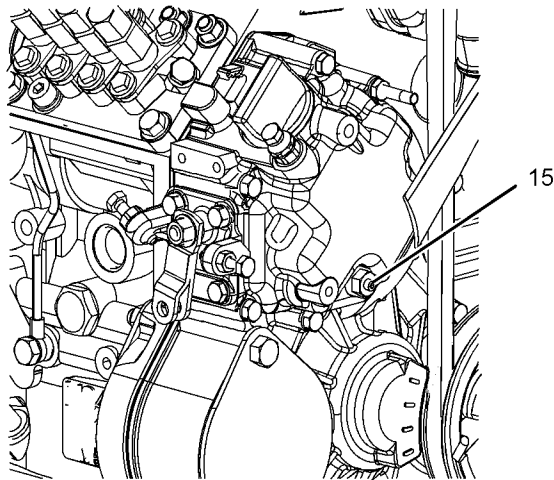

Illustration 68

g01446551

9. Set the Protrusion (X) of the high idle stop screw (4) to the same dimensions as the stop screws on the original front housing.
10. Set the Protrusion (Y) of the low idle stop screw (5) to the same dimensions as the stop screws on the original front housing.
11. Release locknut (3). Set the high idle trimmer screw (2) to the fully out position. Turn the screw clockwise for two turns. Tighten locknut (3).

12. Install the fuel injection pump to the cylinder block. Refer to Disassembly and Assembly, "Fuel Injection Pump - Remove and Install" for the correct procedure.
13. Start the engine and allow the engine to reach normal operating temperature.
14. Run the engine at low idle and adjust the low idle stop screw (5) to the speed that was previously recorded, prior to the original front end removal.
15. Run the engine at high idle and adjust the high idle stop screw (4) to the speed that was previously recorded as "Speed B".
16. Run the engine at high idle and release the locknut (3). Adjust the high idle trimmer screw (2) to the speed that was previously recorded as "Speed A". Tighten the locknut (3).

**Note:** The recorded "Speed A" will be higher than the recorded "Speed B".

17. Ensure correct operation of the engine.
18. Install tamper proof caps (1) to the high idle trimmer screw (2) and the high idle screw (4). Install the tamper proof cap (not shown) to fuel screw (15).

**Note:** Care should be taken when the tamper proof cap is installed to the fuel screw.

## Air Inlet and Exhaust System

i02251899

### Air Inlet and Exhaust System - Inspect

A general visual inspection should be made to the air inlet and exhaust system. Make sure that there are no signs of leaks in the system.

There will be a reduction in the performance of the engine if there is a restriction in the air inlet system or the exhaust system.

#### WARNING

**Hot engine components can cause injury from burns. Before performing maintenance on the engine, allow the engine and the components to cool.**

#### WARNING

**Making contact with a running engine can cause burns from hot parts and can cause injury from rotating parts.**

**When working on an engine that is running, avoid contact with hot parts and rotating parts.**

1. Inspect the engine air cleaner inlet and ducting in order to ensure that the passageway is not blocked or collapsed.
2. Inspect the engine air cleaner element. Replace a dirty engine air cleaner element with a clean engine air cleaner element.
3. Check for dirt tracks on the clean side of the engine air cleaner element. If dirt tracks are observed, contaminants are flowing past the engine air cleaner element and/or the seal for the engine air cleaner element.
4. For engines with plastic valve mechanism covers, if you experience excessive crankcase pressure, remove the valve mechanism cover and check the end of the shroud for a skin of plastic. If the end of the shroud has a skin of plastic, remove the skin of plastic. Ensure that all of the debris is removed.

5. If the breather tube is made of plastic, use low pressure air to check for a blockage in the breather tube. If a blockage is inside of the connector, the cover assembly must be replaced. A broken valve mechanism cover will result if you try to remove the connection.

i08229560

### Wastegate - Test (Turbocharger - Inspect)

#### WARNING

**Hot engine components can cause injury from burns. Before performing maintenance on the engine, allow the engine and the components to cool.**

#### NOTICE

Keep all parts clean from contaminants.

Contaminants may cause rapid wear and shortened component life.

#### NOTICE

Care must be taken to ensure that fluids are contained during performance of inspection, maintenance, testing, adjusting and repair of the product. Be prepared to collect the fluid with suitable containers before opening any compartment or disassembling any component containing fluids.

Dispose of all fluids according to local regulations and mandates.

Before you begin inspection of the turbocharger, be sure that the inlet air restriction is within the specifications for your engine. Be sure that the exhaust system restriction is within the specifications for your engine. Refer to Systems Operation, Testing, and Adjusting, "Air Inlet and Exhaust System - Inspect".

The condition of the turbocharger will have definite effects on engine performance. Use the following inspections and procedures to determine the condition of the turbocharger.

- Inspection of the compressor and the compressor housing
- Inspection of the turbine wheel and the turbine housing
- Inspection of the wastegate

## Inspection of the Compressor and the Compressor Housing

1. Inspect the compressor wheel for damage from a foreign object. If there is damage, determine the source of the foreign object. Replace the turbocharger. If there is no damage, go to step 2.
2. Turn the rotating assembly by hand. While you turn the assembly, push the assembly sideways. The assembly should turn freely. The compressor wheel should not rub the compressor housing. The turbocharger must be replaced if the compressor wheel rubs the compressor wheel housing. If there is no rubbing or scraping, go to step 3.

### NOTICE

A high proportion of engine oil will be removed from the blow-by gas by the oil separator in the valve mechanism cover. In this crankcase breather system, the presence of some oil in the breather connection to the air induction systems and downstream of the compressor in the air inlet connections after service is to be expected.

3. Inspect the compressor and the compressor wheel housing for oil leakage. An oil leak from the compressor may deposit oil in the air inlet connections. If oil is found in the air inlet connections, then drain and clean the air inlet connections.
  - a. Check the oil level in the crankcase. If the oil level is too high or is too low, adjust the oil level.
  - b. Inspect the engine air cleaner element. Replace a dirty engine air cleaner element with a clean engine air cleaner element. Refer to Operation and Maintenance Manual, "Engine Air Cleaner Element - Replace" for the correct procedure. Inspect the engine air cleaner service indicator. Refer to Operation and Maintenance Manual, "Engine Air Cleaner Service Indicator - Inspect" for the correct procedure.
  - c. Inspect the engine crankcase breather. Clean the engine crankcase breather or replace the engine crankcase breather if the engine crankcase breather is plugged.
  - d. Remove the pipe for the oil drain. Inspect the drain opening. Inspect the oil drain line. Inspect the area between the bearings of the rotating assembly shaft. Look for the oil sludge. Inspect the oil drain hole for the oil sludge. Inspect the oil drain line for the oil sludge in the drain line. If necessary, clean the oil drain line. Replace the oil drain line if there is any sign of damage to the oil drain line.

- e. If steps 3a through 3d did not reveal the source of the oil leakage, the turbocharger has internal damage. Replace the turbocharger.

## Inspection of the Turbine Wheel and the Turbine Housing

Remove the air piping from the turbine housing.

1. Inspect the turbine for damage by a foreign object. If there is damage, determine the source of the foreign object. Replace the turbocharger. If there is no damage, go to step 2.
2. Inspect the turbine wheel for the carbon and other foreign material. Inspect turbine housing for carbon and foreign material. Replace the turbocharger, if necessary. If there is no buildup of carbon or foreign material, go to step 3.
3. Turn the rotating assembly by hand. While you turn the assembly, push the assembly sideways. The assembly should turn freely. The turbine wheel should not rub turbine wheel housing. Replace the turbocharger if the turbine wheel rubs turbine housing. If there is no rubbing or scraping, go to step 4.
4. Inspect the turbine and turbine housing for oil leakage. Inspect the turbine and turbine housing for oil coking. Some oil coking may be cleaned. Heavy oil coking may require replacement of the turbocharger. If the oil is coming from the turbocharger center housing go to step 4a.
  - a. Remove the pipe for the oil drain. Inspect the drain opening. Inspect the area between the bearings of the rotating assembly shaft. Look for the oil sludge. Inspect the oil drain hole for the oil sludge. Inspect the oil drain line for the oil sludge. If necessary, clean the drain line.
  - b. If crankcase pressure is high, or if the oil drain is restricted, pressure in the center housing may be greater than the pressure of turbine housing. Oil flow may be forced in the wrong direction and the oil may not drain. Check the crankcase pressure and correct any problems.
  - c. If the oil drain line is damaged, replace the oil drain line.
  - d. Check the routing of the oil drain line. Eliminate any sharp restrictive bends. Make sure that the oil drain line is not too close to the engine exhaust manifold.
- e. If steps 4a through 4d did not reveal the source of the oil leakage, turbocharger has internal damage. Replace the turbocharger.

## Inspection of the Wastegate

The wastegate actuator controls the amount of exhaust gas that is allowed to bypass the turbine side of the turbocharger. This valve then controls the rpm of the turbocharger.

When the engine operates in conditions of a low boost (lug), a spring presses against a diaphragm in the canister. The load on the spring holds the wastegate closed. The turbocharger can then operate at maximum performance.

When the boost pressure increases against the diaphragm in the canister, the wastegate will open. The rpm of the turbocharger becomes limited. The rpm is limited because a portion of the exhaust gases bypasses the turbine wheel of the turbocharger.

The following levels of boost pressure indicate a problem with the wastegate:

- Too high in full load conditions
- Too low in all low boost conditions

The boost pressure controls the maximum rpm of the turbocharger, because the boost pressure controls the position of the wastegate. The following factors also affect the maximum rpm of the turbocharger:

- The engine rating
- The power demand on the engine
- The high idle rpm
- Inlet air restriction
- Exhaust system restriction

**Note:** The turbocharger is a nonserviceable item. The pressure for the wastegate can be checked but not adjusted.

## Check the Wastegate for Correct Operation

Table 5

Required Tools			
Tool	Part Number	Part Description	Qty
A	21825617	Dial Indicator Group	1

1. If necessary, remove the heat shield from the turbocharger. Remove the guard for the wastegate.
2. Remove the boost line from the wastegate. Connect an air supply to the wastegate that can be adjusted accurately.

3. Install Tooling (A) to the turbocharger so that the end of the actuator rod is in contact with the plunger of the dial gauge. This will measure axial movement of the actuator rod.
4. Slowly apply air pressure to the wastegate so that the actuator rod moves the required amount. Refer to Specifications, Turbocharger for the correct values. Ensure that the dial gauge returns to zero when the air pressure is released. Repeat the test several times. This will ensure that an accurate reading is obtained.
5. If the operation of the wastegate is not correct, the turbocharger will need to be replaced.

i02184786

## Compression - Test

### Compression

The following conditions can affect the results of the cylinder compression test:

- The battery is in good condition.
- The battery is fully charged.
- The starter motor operates correctly.
- The valve lash is set correctly.
- The compression gauge is accurate.

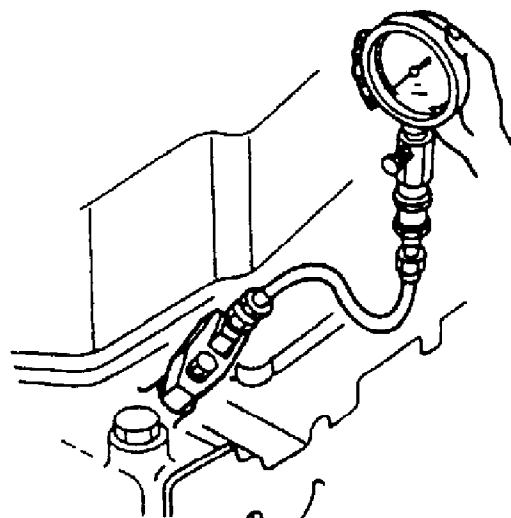

Illustration 69

Checking compression of the engine

g00564993

1. Remove the fuel injector from the cylinder in order to measure the compression for that cylinder.
2. Connect a suitable compression gauge to the cylinder.
3. Disconnect the fuel shutoff solenoid.
4. Operate the starter motor and record the pressure on the compression gauge.
5. Repeat for each cylinder.

**Note:** Compression tests should only be used to compare pressures between cylinders of an engine. If one or more cylinders vary more than 350 kPa (51 psi) then those cylinders may be damaged.

**Note:** The cylinder compression test should not be the only test for determining the condition of an engine.

Table 6

	Standard at Assembly	Repair Limit
Compression Pressure <sup>(1)</sup>	2940 kPa (426 psi)	2450 kPa (355 psi)

<sup>(1)</sup> The compression pressure is taken at 250 rpm.

6. Repair procedures must be taken if the compression is lower than the repair limit.

**NOTICE**

Be sure to measure the compression on all of the cylinders. If all of the cylinders are not checked an improper diagnosis may result. The compression pressure will vary with the change in engine rpm. It is necessary to keep the engine rpm constant for all cylinders when you are taking a compression reading.

i06943692

## Engine Valve Lash - Inspect/Adjust

**⚠ WARNING**

To prevent possible injury, do not use the starter to turn the flywheel.

Hot engine components can cause burns. Allow additional time for the engine to cool before measuring valve clearance.

### Valve Lash Setting

The valve lash setting is for a cold engine.

#### Valve lash setting

- Inlet valve . . . . . 0.2 ± 0.05 mm  
((0.008 ± 0.0020 inch))
- Exhaust valve . . . . . 0.2 ± 0.05 mm  
((0.008 ± 0.0020 inch))

### Valve Lash Adjustment

If the valve lash requires adjustment several times in a short time period, excessive wear exists in a different part of the engine. Repair the problem to prevent more damage to the engine.

Not enough valve lash can be the cause of rapid wear of the camshaft and valve lifters. Not enough valve lash can indicate that the seats for the valves are worn.

Valves become worn due to the following causes:

- Incorrect operation of fuel injectors
- Excessive dirt and oil are present on the filters for the inlet air.
- Incorrect fuel settings on the fuel injection pump.
- The load capacity of the engine is frequently exceeded.

Too much valve lash can cause broken valve stems, springs, and spring retainers. Too much valve lash can be an indication of the following problems:

- Worn camshaft and valve lifters
- Worn rocker arms
- Bent pushrods
- Broken socket on the upper end of a pushrod
- Loose adjustment screw for the valve lash

If the camshaft and valve lifters show rapid wear, look for fuel in the lubrication oil or dirty lubrication oil as a possible cause.

The valve lash is measured between the top of the valve stem and the rocker arm lever.

**Note:** No. 1 cylinder is at the front of the engine.

Remove the valve mechanism cover and perform the following procedures to adjust the valve lash:

**Note:** When these procedures are performed, the front housing must be installed.

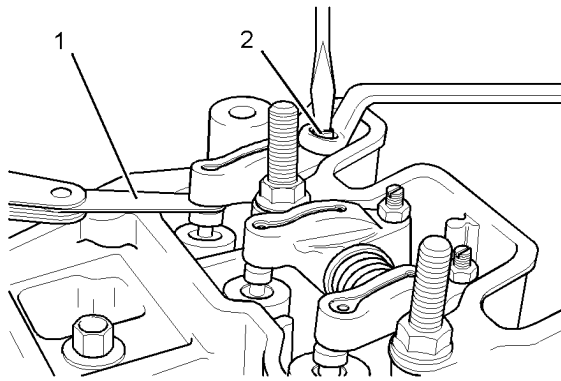

Illustration 70

g01107989

### Setting the valve lash

- (1) Feeler gauge  
(2) Adjustment screw

## **⚠ WARNING**

**Accidental engine starting can cause injury or death to personnel.**

**To prevent accidental engine starting, turn the ignition switch to the OFF position, place a do not operate tag at the ignition switch location and disconnect and tape the electrical connection to the stop solenoid that is located on the fuel injection pump.**

## Valve Lash Adjustment for Two Cylinder Engines

1. Rotate the crankshaft in a clockwise direction that is viewed from the front of the engine. When the inlet valve of the No. 1 cylinder has started to open and the exhaust valve of the No. 1 cylinder has not completely closed, check the valve lash of the inlet valve of No. 2 cylinder and the exhaust valve of No. 2 cylinder. If necessary, make adjustment.
  - a. Loosen the valve adjustment screw locknut that is on adjustment screw (2).
  - b. Place the appropriate feeler gauge (1) between the rocker arm and the valve. Turn adjustment screw (2) while the valve adjustment screw locknut is being held from turning. Adjust the valve lash until the correct specification is achieved.
  - c. After each adjustment, tighten the valve adjustment screw locknut while adjustment screw (2) is being held from turning.

2. Rotate the crankshaft in a clockwise direction that is viewed from the front of the engine. When the inlet valve of the No. 2 cylinder has started to open and the exhaust valve of the No. 2 cylinder has not completely closed, check the valve lash of the inlet valve for No. 1 cylinder and the exhaust valve for No. 1 cylinder.

If adjustment is necessary, refer to Steps 1a, 1b, and 1c above.

## Valve Lash Adjustment for Three Cylinder Engines

1. Rotate the crankshaft in a clockwise direction that is viewed from the front of the engine. When the inlet valve of the No. 1 cylinder has started to open and the exhaust valve of the No. 1 cylinder has not completely closed, check the valve lash of the inlet valve of No. 2 cylinder and the exhaust valve of No. 3 cylinder. If necessary, make adjustment.
  - a. Loosen the valve adjustment screw locknut that is on adjustment screw (2).
  - b. Place the appropriate feeler gauge (1) between the rocker arm and the valve. Turn adjustment screw (2) while the valve adjustment screw locknut is being held from turning. Adjust the valve lash until the correct specification is achieved.
  - c. After each adjustment, tighten the valve adjustment screw locknut while adjustment screw (2) is being held from turning.
2. Rotate the crankshaft in a clockwise direction that is viewed from the front of the engine. When the inlet valve of the No. 2 cylinder has started to open and the exhaust valve of the No. 2 cylinder has not completely closed, check the valve lash of the inlet valve for No. 3 cylinder and the exhaust valve for No. 1 cylinder.
 

If adjustment is necessary, refer to Steps 1a, 1b, and 1c above.
3. Rotate the crankshaft in a clockwise direction that is viewed from the front of the engine. When the inlet valve of the No. 3 cylinder has started to open and the exhaust valve of the No. 3 cylinder has not completely closed, check the valve lash of the inlet valve for No. 1 cylinder and the exhaust valve for No. 2 cylinder.

If adjustment is necessary, refer to Steps 1a, 1b, and 1c above.

i02193792

## Valve Depth - Inspect

Table 7

Required Tools		
Part Number	Part Description	Qty
21825617	Dial gauge	1
21825496	Dial gauge holder	1

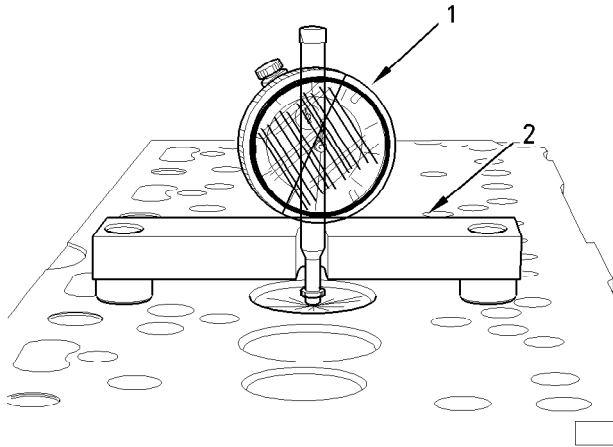

Illustration 71

g00953530

- (1) Dial gauge  
(2) Dial gauge holder

1. Use the dial gauge (1) with the dial gauge holder (2) to check the depths of the inlet valves and the exhaust valves below the face of the cylinder head. Use the cylinder head face (3) to zero the dial gauge (1).
2. Position the dial gauge holder (2) and the dial gauge (1) in order to measure the valve depth. Measure the depth of the inlet valve and the exhaust valve before the valve springs are removed.

Refer to Specifications, "Cylinder Head Valves" for the minimum, the maximum, and the service wear limits for the valve depth below the cylinder head face.

If the valve depth below the cylinder head face exceeds the service limit, use a new valve to check the valve depth. If the valve depth still exceeds the service limit, renew the cylinder head or renew the valve seat inserts (if equipped). If the valve depth is within the service limit, renew the valves.

3. Inspect the valves for cracks and other damage. Check the valve stems for wear. Check that the valve springs are the correct length under the test force. Refer to Specifications, "Cylinder Head Valves" for the dimensions and tolerances of the valves and valve springs.

i07991900

## Valve Guide - Inspect

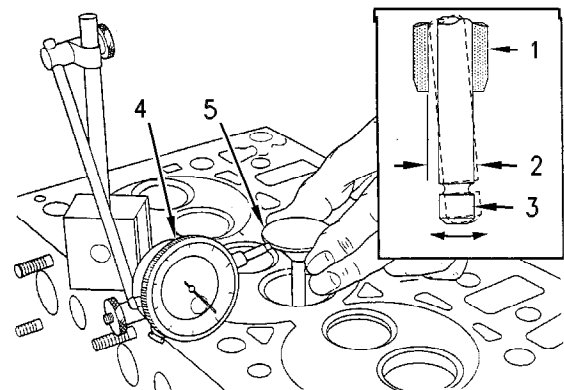

Illustration 72

g00314806

### Typical example

- (1) Valve guide  
(2) Radial movement of the valve in the valve guide  
(3) Valve stem  
(4) Dial indicator  
(5) Valve head

1. Place a new valve in the valve guide.
2. Place the dial indicator with the magnetic base on the face of the cylinder head.
3. Lift the edge of the valve head to a distance of 15.0 mm (0.60 inch).
4. Move the valve in a radial direction away from the dial indicator. Make sure that the valve moves away from the dial indicator as far as possible. Position the contact point of the dial indicator on the edge of the valve head. Set the position of the needle of the dial indicator to zero.

5. Move the valve in a radial direction toward the dial indicator as far as possible. Note the distance of movement which is indicated on the dial indicator. Determine if the distance is greater than the maximum clearance of the valve in the valve guide. Refer to Specifications, "Cylinder Head Valves" for the maximum clearance of the valve in the valve guide.

# Lubrication System

i02193793

## Engine Oil Pressure - Test

An oil pressure gauge that has a defect can indicate low oil pressure.

Use a suitable gauge that measures the oil pressure in the engine.

1. Ensure that the engine is filled to the correct oil level.
2. Connect the gauge to a pressure tap location for engine oil.
3. Operate the engine. Allow the engine to obtain normal operating temperature.
4. Keep the oil temperature constant with the engine at the rated rpm. Read the pressure gauge.
5. Refer to Table 8 in order to determine if the engine oil pressure is in tolerance.

Table 8

Oil Pressure <sup>(1)</sup>	
Oil Pressure at high idle	196 to 441 kPa (28.4 to 64 psi)
Oil Pressure at low idle	49 kPa (7.1 psi) or more

<sup>(1)</sup> The oil temperature must be 80° to 110°C (176° to 230°F).

Troubleshoot the cause of the problem and correct the problem if the results of the test do not fall within the pressure range in Table 8. Engine failure or a reduction in engine life can be the result if engine operation is continued with oil pressure outside this range.

**Note:** A record of engine oil pressure at regular intervals can be used as an indication of possible problems of the engine. A record of engine oil pressure at regular intervals can also be used as an indication of possible damage to the engine. The engine should be inspected and the problem should be corrected if there is a sudden increase or a sudden decrease of 70 kPa (10 psi) in oil pressure.

i02617860

## Engine Oil Pump - Inspect

If any part of the engine oil pump is worn enough in order to affect the performance of the engine oil pump, the engine oil pump must be replaced.

Perform the following procedures in order to inspect the engine oil pump. Refer to Specifications, "Engine Oil Pump".

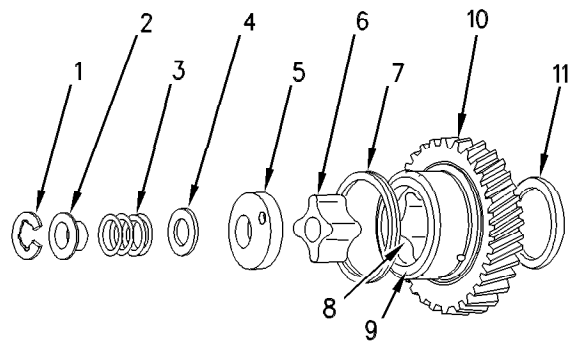

Illustration 73

g00458938

### Idle gear and components of the engine oil pump

- (1) C-clip
- (2) Collar
- (3) Spring
- (4) Shim
- (5) Oil pump cover
- (6) Inner rotor
- (7) Spring
- (8) Outer rotor
- (9) Bushing
- (10) Idler gear
- (11) Thrust washer

1. Remove the front housing. Remove C-clip (1).

**Note:** If the front housing is removed, do not turn the crankshaft.

2. Disassemble the engine oil pump. Refer to Disassembly and Assembly, "Engine Oil Pump - Remove" for additional information. Do not remove bushing (9) from idler gear (10) unless damage is observed.

3. Clean all of the parts and inspect the parts for cracks in the metal or other damage. Look for wear on the components. Ensure that bushing (9) is not loose in idler gear (10).

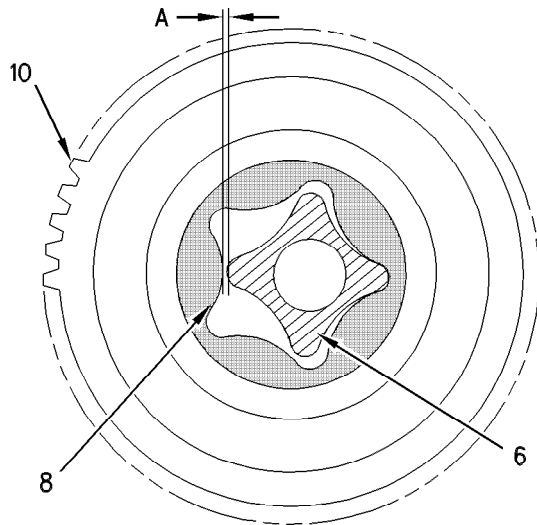

Illustration 74 g00459701  
Clearance between the inner rotor and the outer rotor

4. Install the idler gear and the inner rotor on the shaft. Measure clearance (A) between inner rotor (6) and outer rotor (8).

Refer to Specifications, "Engine Oil Pump".

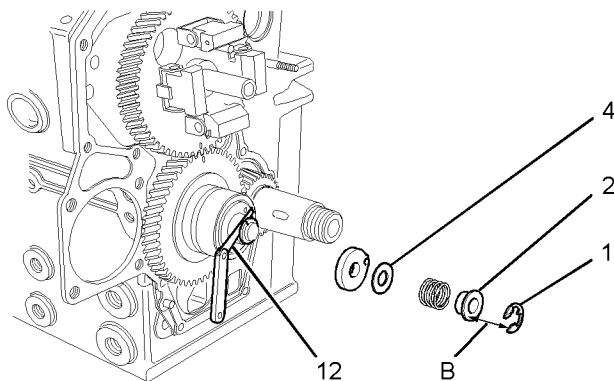

Illustration 75 g01290817  
Face of the cover for the oil pump above the face of the idler gear

- (1) C-clip  
(2) Collar  
(4) Shim  
(12) Feeler gauge

5. Use feeler gauge (12) to measure the distance between C-clip (1) and collar (2).

6. When the components of the engine oil pump are installed on the front housing, measurement (B) between C-clip (1) and collar (2) must be between 0.10 to 0.15 mm (0.004 to 0.006 inch) for new components. Dimension B must be not more than 0.20 mm (0.008 inch) for used parts.

The distance between the faces is adjusted with shims (4). The thicknesses of the shims are given in Specifications, "Engine Oil Pump".

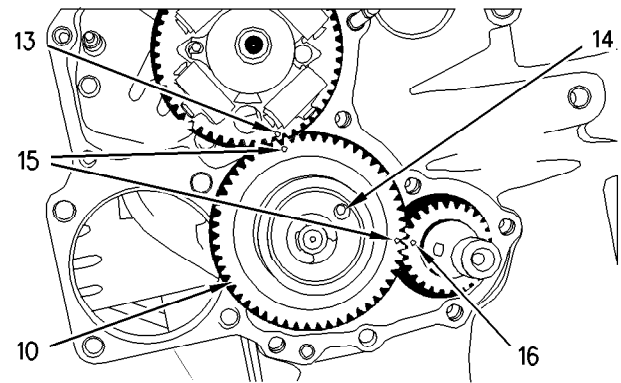

Illustration 76 g00826185

7. Install the components of the engine oil pump and the front housing on the cylinder block. Make sure that the two dowels align with the bushing, the outer rotor, and the holes in the idler gear.

Align the timing mark (15) on idler gear (10) with the timing mark on crankshaft gear (16) when you install the idler gear on the oil pump shaft. Also, align the other timing mark (15) on idler gear (10) with the timing mark on the camshaft gear (13). The hole (14) in oil pump cover (5) should align with the locating pin in the front housing.

**Note:** When the front housing is not installed on the engine, do not rotate the crankshaft.

i07964341

## Excessive Bearing Wear - Inspect

### Introduction

Use the following procedure to inspect for excessive bearing wear.

When some components of the engine show bearing wear in a short time, the cause can be a restriction in an oil passage.

## Inspection Procedure

An engine oil pressure indicator may show that there is enough oil pressure, but a component is worn due to a lack of lubrication. In such a case, look at the passage for the oil supply to the component. A restriction in an oil supply passage will not allow enough lubrication to reach a component. This restriction will result in early wear.

Excessive consumption of engine oil can also result if engine oil with the wrong viscosity is used. Engine oil with a thin viscosity can be caused by increased engine temperature.

i08265791

## Excessive Engine Oil Consumption - Inspect

### Introduction

The procedures listed below are for inspecting engine components that can cause excessive engine oil consumption.

### Engine Oil Leaks on the Outside of the Engine

Check for leakage at the seals at each end of the crankshaft. Look for leakage at the gasket for the engine oil pan and all lubrication system connections. Look for any engine oil that may be leaking from the crankcase breather. This can be caused by combustion gas leakage around the pistons. A dirty crankcase breather will cause high pressure in the crankcase. A dirty crankcase breather will cause the gaskets and the seals to leak.

### Engine Oil Leaks into the Combustion Area of the Cylinders

Engine oil that is leaking into the combustion area of the cylinders can be the cause of blue smoke. There are several possible ways for engine oil to leak into the combustion area of the cylinders:

- Leaks between worn valve guides and valve stem
- Worn components or damaged components (pistons, piston rings, or dirty return holes for the engine oil)
- Incorrect installation of the compression ring and/or the intermediate ring
- Leaks past the seal rings in the turbocharger shaft
- Overfilling of the crankcase
- Wrong oil level gauge or guide tube
- Sustained operation at light loads

# Cooling System

i02193795

## Cooling System - Check (Overheating)

Above normal coolant temperatures can be caused by many conditions. Use the following procedure to determine the cause of above normal coolant temperatures:

1. Check the coolant level in the cooling system. If the coolant level is too low, air will get into the cooling system. Air in the cooling system will cause a reduction in coolant flow and bubbles in the coolant. Air bubbles will keep the coolant away from the engine parts, which will prevent the transfer of heat to the coolant. Low coolant level is caused by leaks or incorrectly filling the expansion tank.
2. If contamination of the coolant is suspected, refer to Operation and Maintenance, "Maintenance Section" for the correct specification of coolant.
3. Check for air in the cooling system. Air can enter the cooling system in different ways. The most common causes of air in the cooling system are not filling the cooling system correctly and combustion gas leakage into the cooling system. Combustion gas can get into the system through inside cracks, a damaged cylinder head, or a damaged cylinder head gasket. Air in the cooling system causes a reduction in coolant flow and bubbles in the coolant. Air bubbles keep the coolant away from the engine parts, which prevents the transfer of heat to the coolant.
4. Check the sending unit. In some conditions, the temperature sensor in the engine sends signals to a sending unit. The sending unit converts these signals to an electrical impulse which is used by a mounted gauge. If the sending unit malfunctions, the gauge can show an incorrect reading. Also if the electric wire breaks or if the electric wire shorts out, the gauge can show an incorrect reading.
5. Check the radiator.
  - a. Check the radiator for a restriction to coolant flow. Check the radiator for debris, dirt, or deposits on the inside of the core. Debris, dirt, or deposits will restrict the flow of coolant through the radiator.
  - b. Check for debris or damage between the fins of the radiator core. Debris between the fins of the radiator core restricts air flow through the radiator core. Refer to Testing and Adjusting, "Cooling System - Inspect".
6. Check the filler cap. A pressure drop in the cooling system can cause the boiling point to be lower. This can cause the cooling system to boil. Refer to Testing and Adjusting, "Cooling System - Test".
7. Check the fan and/or the fan shroud. The fan shroud must be the proper size and the fan shroud must be positioned correctly.
8. Check for loose drive belts.
  - a. A loose fan drive belt will cause a reduction in the air flow across the radiator. Check the fan drive belt for proper belt tension. Adjust the tension of the fan drive belt, if necessary. Refer to the Testing and Adjusting Section, "Belt Tension Chart".
  - b. A loose water pump drive belt will cause a reduction in coolant flow through the radiator. Check the water pump drive belt for proper belt tension. Adjust the water pump drive belt's tension, if necessary. Refer to the Testing and Adjusting Section, "Belt Tension Chart".
9. Check the cooling system hoses and clamps. Damaged hoses with leaks can normally be seen. Hoses that have no visual leaks can soften during operation. The soft areas of the hose can become kinked or crushed during operation. These areas of the hose can cause a restriction in the coolant flow. Hoses become soft and/or get cracks after a period of time. The inside of a hose can deteriorate, and the loose particles of the hose can cause a restriction of the coolant flow.
10. Check for a restriction in the air inlet system. A restriction of the air that is coming into the engine can cause high cylinder temperatures. High cylinder temperatures require higher than normal temperatures in the cooling system.
11. Check for a restriction in the exhaust system. A restriction of the air that is coming out of the engine can cause high cylinder temperatures.
  - a. Make a visual inspection of the exhaust system.
  - b. Check for damage to exhaust piping. Check for damage to the exhaust elbow. If no damage is found, check the exhaust system for a restriction.

12. Check the water temperature regulator. A water temperature regulator that does not open, or a water temperature regulator that only opens part of the way can cause overheating. Refer to Testing and Adjusting, "Water Temperature Regulator - Test".
13. Check the water pump. A water pump with a damaged impeller does not pump enough coolant for correct engine cooling. Remove the water pump and check for damage to the impeller.
14. Consider high outside temperatures. When outside temperatures are too high for the rating of the cooling system, there is not enough of a temperature difference between the outside air and coolant temperatures. The maximum temperature of the ambient air that enters the engine should not exceed 50 °C (120 °F).
15. When a load that is applied to the engine is too large, the engine rpm does not increase with an increase of fuel. This lower engine rpm causes a reduction in coolant flow through the system. This combination of less air and less coolant flow during high input of fuel will cause above normal heating.
16. Timing of the engine which is incorrect may also cause overheating of the engine. Late timing creates more heat in the engine. Early timing creates less heat in the engine.

**Note:** If the timing of the engine is incorrect, the exhaust valves may be burned and damage to the exhaust manifold may occur.

i01300404

## Cooling System - Inspect

Cooling systems that are not regularly inspected are the cause for increased engine temperatures. Make a visual inspection of the cooling system before any tests are performed.

### **WARNING**

**Personal injury can result from escaping fluid under pressure.**

**If a pressure indication is shown on the indicator, push the release valve in order to relieve pressure before removing any hose from the radiator.**

1. Check the coolant level in the cooling system.
2. Look for leaks in the system.

**Note:** A small amount of coolant leakage across the surface of the water pump seals is normal. This leakage is required in order to provide lubrication for this type of seal. A hole is provided in the water pump housing in order to allow this coolant/seal lubricant to drain from the pump housing. Intermittent leakage of small amounts of coolant from this hole is not an indication of water pump seal failure.

3. Make sure that air flow through the radiator does not have a restriction. Look for bent core fins between the folded cores of the radiator. Also, look for debris between the folded cores of the radiator.
4. Inspect the drive belts for the fan.
5. Check for damage to the fan blades.
6. Look for air or combustion gas in the cooling system.
7. Inspect the filler cap, and check the surface that seals the filler cap. This surface must be clean.
8. Look for large amounts of dirt in the radiator core. Look for large amounts of dirt on the engine. Remove the dirt from the radiator core and the engine.
9. Fan shrouds that are loose or missing cause poor air flow for cooling.

i01964006

## Cooling System - Test

Remember that temperature and pressure work together. When a diagnosis is made of a cooling system problem, temperature and pressure must be checked. The cooling system pressure will have an effect on the cooling system temperature. For an example, refer to Illustration 77 . This will show the effect of pressure on the boiling point (steam of water. This will also show the effect of height above sea level.

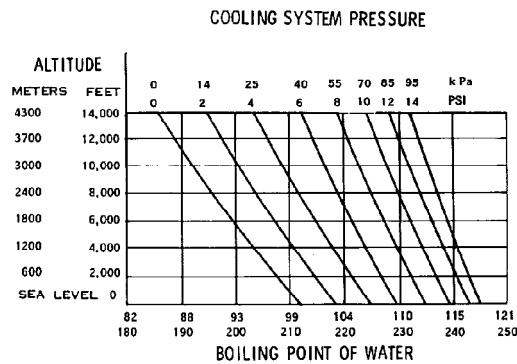

Illustration 77

g00286266

Cooling system pressure at specific altitudes and boiling points of water

### **⚠ WARNING**

Personal injury can result from hot coolant, steam and alkali.

At operating temperature, engine coolant is hot and under pressure. The radiator and all lines to heaters or the engine contain hot coolant or steam. Any contact can cause severe burns.

Remove filler cap slowly to relieve pressure only when engine is stopped and radiator cap is cool enough to touch with your bare hand.

The coolant level must be to the correct level in order to check the coolant system. The engine must be cold and the engine must not be running.

After the engine is cool, loosen the pressure cap in order to relieve the pressure out of the cooling system. Then remove the pressure cap.

The level of the coolant should not be more than 13 mm (0.5 inch) from the bottom of the filler pipe. If the cooling system is equipped with a sight glass, the coolant should be to the correct level in the sight glass.

## Checking the Filler Cap

One cause for a pressure loss in the cooling system can be a faulty seal on the radiator pressure cap.

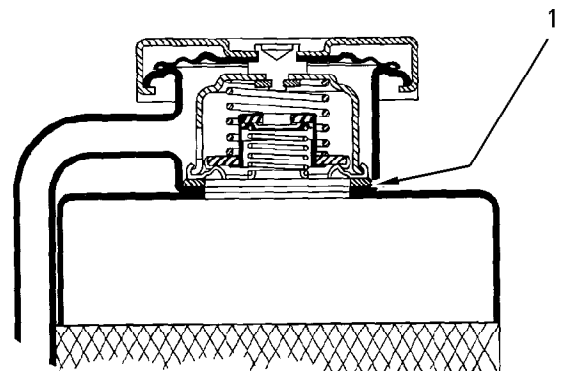

Illustration 78

g00296067

Typical schematic of filler cap

(1) Sealing surface between the pressure cap and the radiator

### **⚠ WARNING**

Personal injury can result from hot coolant, steam and alkali.

At operating temperature, engine coolant is hot and under pressure. The radiator and all lines to heaters or the engine contain hot coolant or steam. Any contact can cause severe burns.

Remove filler cap slowly to relieve pressure only when engine is stopped and radiator cap is cool enough to touch with your bare hand.

To check for the amount of pressure that opens the filler cap, use the following procedure:

1. After the engine cools, carefully loosen the filler cap. Slowly release the pressure from the cooling system. Then, remove the filler cap.
2. Inspect the pressure cap carefully. Look for damage to the seal. Look for damage to the surface that seals. Remove any debris on the cap, the seal, or the sealing surface.

Carefully inspect the filler cap. Look for any damage to the seals and to the sealing surface. Inspect the following components for any foreign substances:

- Filler cap
- Seal
- Surface for seal

Remove any deposits that are found on these items, and remove any material that is found on these items.

3. Install the pressure cap onto a suitable pressurizing Pump.

4. Observe the exact pressure that opens the filler cap.
5. Compare the pressure to the pressure rating that is found on the top of the filler cap.
6. If the filler cap is damaged, replace the filler cap.

## Testing The Radiator And Cooling System For Leaks

Use the following procedure to test the radiator and the cooling system for leaks.

### WARNING

Personal injury can result from hot coolant, steam and alkali.

At operating temperature, engine coolant is hot and under pressure. The radiator and all lines to heaters or the engine contain hot coolant or steam. Any contact can cause severe burns.

Remove filler cap slowly to relieve pressure only when engine is stopped and radiator cap is cool enough to touch with your bare hand.

1. When the engine has cooled, loosen the filler cap to the first stop. Allow the pressure to release from the cooling system. Then remove the filler cap.
2. Make sure that the coolant covers the top of the radiator core.
3. Put a suitable pressurizing Pump onto the radiator.
4. Use the pressurizing pump to increase the pressure to an amount of 20 kPa (3 psi) more than the operating pressure of the filler cap.
5. Check the radiator for leakage on the outside.
6. Check all connections and hoses of the cooling system for leaks.

The radiator and the cooling system do not have leakage if all of the following conditions exist:

- You do NOT observe any leakage after five minutes.
- The dial indicator remains constant beyond five minutes.

The inside of the cooling system has leakage only if the following conditions exist:

- The reading on the gauge goes down.
- You do NOT observe any outside leakage.

Make any repairs, as required.

i07814425

## Water Temperature Regulator - Test

### WARNING

Personal injury can result from escaping fluid under pressure.

If a pressure indication is shown on the indicator, push the release valve in order to relieve pressure before removing any hose from the radiator.

## References

**Reference:** Refer to Specifications, "Water Temperature Regulator" for information on the water temperature regulator.

## Introduction

Use this procedure to test the water temperature regulator.

## Test Preparation

1. Remove the water temperature regulator from the engine.
2. Heat water in a pan until the temperature of the water is equal to the fully open temperature of the water temperature regulator. Refer to Specifications, "Water Temperature Regulator" for the fully open temperature of the water temperature regulator.
3. Stir the water in the pan. This will distribute the temperature throughout the pan.

## Test Procedure

1. Hang the water temperature regulator in the pan of water. The water temperature regulator must be below the surface of the water. The water temperature regulator must be away from the sides and the bottom of the pan.
2. Keep the water at the correct temperature for 10 minutes.

- After 10 minutes, remove the water temperature regulator. Immediately measure the opening of the water temperature regulator. Refer to Specifications, "Water Temperature Regulator" for the minimum opening distance of the water temperature regulator at the fully open temperature.

If the distance is less than the amount listed in the manual, replace the water temperature regulator.

i09646899

## Water Pump - Inspect

- Inspect the exterior components of the cooling system for coolant leakage. Refer to Systems Operation Testing and Adjusting, Cooling System - Check and Systems Operation Testing and Adjusting, Cooling System - Inspect for more information.

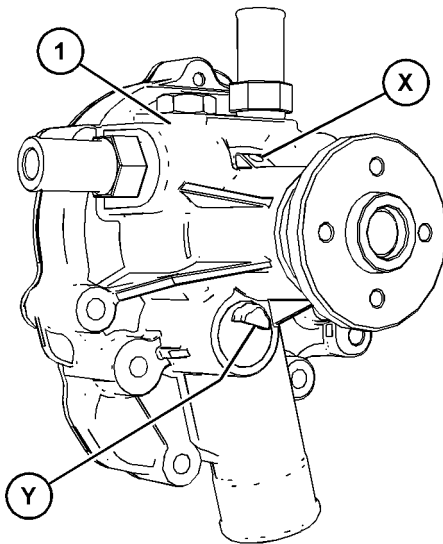

Illustration 79

g07525306

Typical example

- If water pump (1) is leaking coolant and grease from the vent hole in Position (X), Perkins recommends that the water pump is replaced. Refer to Disassembly and Assembly for the correct procedure.

**Note:** A coolant leak from the vent hole in Position (X) means that the weep chamber is full, the weep hole in Position (Y) is blocked. Coolant may have entered the water pump bearing. The water pump bearing may eventually fail due to insufficient lubrication.

**Note:** A coolant leak from vent hole in Position (X) indicates that the coolant has entered the water pump bearing. The coolant may have washed away some of the grease for the water pump bearing, a failure of the water pump bearing may be imminent.

- If the water pump is leaking coolant from vent hole in Position (Y), the coolant leak needs to be investigated.

**Note:** A small amount of coolant leakage across the surface of the seal for the jacket water pump is normal. This leakage is required to provide lubrication for this type of seal. A hole is provided in the water pump housing to allow this coolant/seal lubricant to drain from the water pump housing. Intermittent leakage of small amounts of coolant from this hole is not an indication of water pump seal failure.

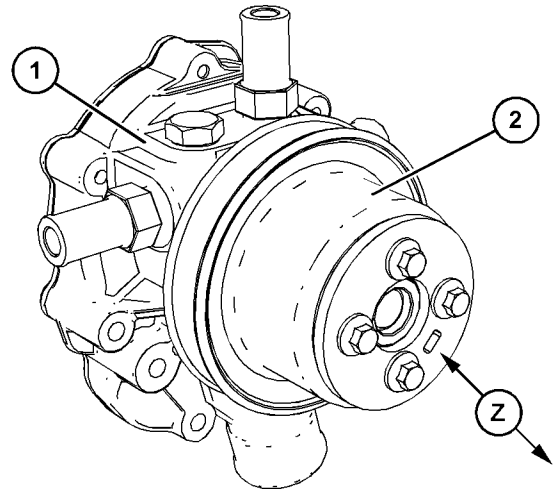

Illustration 80

g07525320

Typical example

- To inspect the water pump (1) further, follow step 4a through to step 4f.
  - If necessary, clean the stain on the water pump (1) and the surrounding area. Ensure that both the weep hole and vent hole are clear and are free from obstructions. Refer to illustration 79 .
  - Check for axial play by pushing and pulling of the water pump pulley (2) in Direction (Z). Feelable play is likely due to water pump bearing failure. Perkins recommends that the water pump is replaced. Refer to Disassembly and Assembly for the correct procedure.
  - Pressurize the cooling system using radiator/shunt tank filler neck adaptor and a source of

compressed air. Ensure that the pressure of the compressed air is not greater than the pressure rating of the radiator filler cap. Check for leaks all over cooling system (not only the water pump). Pay particular attention to rubber hoses and joints. A steady stream of coolant leakage out of weep hole or vent hole of the water pump indicates a seal failure. Perkins recommends that the water pump is replaced. Refer to Disassembly and Assembly for the correct procedure. Seeping around weep plug or a drop of fluid appearing at the weep hole may indicate debris between sealing faces but is not necessarily a sign of water pump seal failure. Refer to Systems Operation Testing and Adjusting, Cooling System - Check and Systems Operation Testing and Adjusting, Cooling System - Inspect for the correct procedures.

- d. If necessary, clean the stains on the cooling system components. Start the engine. Operate the engine up to normal operating temperature. There may be the need to increase engine speed, or increase engine load to increase the engine temperature gradually. Once the normal operating temperature has been reached, reduce engine load and speed. Stop the engine. Remove radiator covers. Allow the engine temperature to cool. Check for leaks around the weep hole and the weep chamber plugs. Clean the cooling system components if any leak is present and repeat.
- e. If a leak reappears, it is likely that either the water pump seal is damaged or that the cooling system is contaminated with solid debris (or both). In there is system contamination, a water pump replacement will not solve the water pump leak problem. Drain and flush the cooling system. Replace the coolant with the correct specification of coolant. Refer to Operation and Maintenance Manual for more information. If the cooling system is clean, Perkins recommends that the water pump is replaced. Refer to Disassembly and Assembly for the correct procedure.
- f. If no leak is observed, after repeated hot shutdowns on a stationary application, it is likely the leak is related to the operation of the application.

## Basic Engine

i07381413

### Piston Ring Groove - Inspect

#### Inspect the Piston and the Piston Rings

1. Check the piston for wear and other damage.
2. Check that the piston rings are free to move in the grooves and that the rings are not broken.

#### Inspect the Clearance of the Piston Ring

1. Remove the piston rings and clean the grooves and the piston rings.

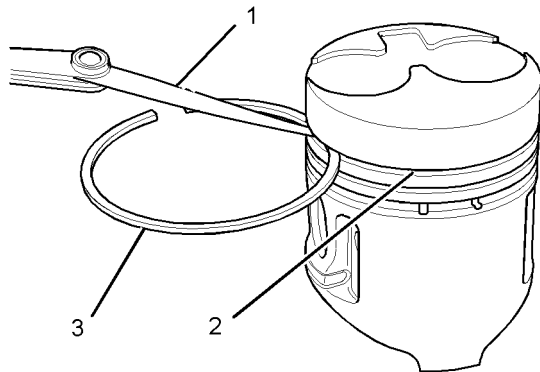

Illustration 81

g01109213

- (1) Feeler gauge  
(2) Piston grooves  
(3) Piston ring

2. Fit new piston rings (3) in the piston grooves (2).
3. Check the clearance for the piston ring by placing a suitable feeler gauge (1) between piston groove (2) and the top of piston ring (3). Refer to Specifications, "Piston and Rings" for the dimensions.

**Note:** On 403J-17T engine, the pistons have a tapered top groove and the piston ring is wedged. The clearance for the top piston ring cannot be checked by the above method when this occurs.

### Inspect the Piston Ring End Gap

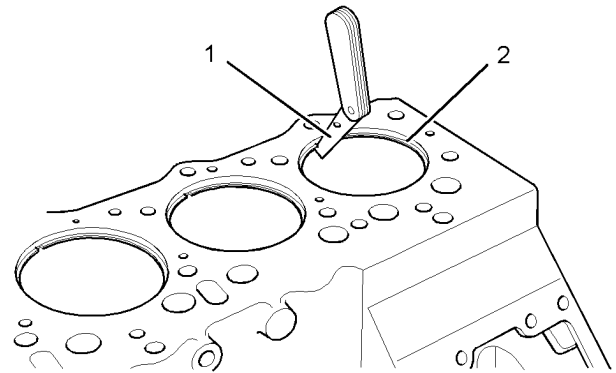

Illustration 82

g01109214

- (1) Feeler gauge  
(2) Piston ring

1. Clean all carbon from the top of the cylinder bores.
2. Place each piston ring (2) in the cylinder bore.
3. Use a suitable feeler gauge (1) to measure piston ring end gap. Refer to Specifications, "Piston and Rings" for the dimensions.

**Note:** The coil spring must be removed from the oil control ring before the gap of the oil control ring is measured.

i02193842

### Connecting Rod - Inspect

This procedure determines the following characteristics of the connecting rod:

- The distortion of the connecting rod
- The parallel alignment of the bores of the connecting rod

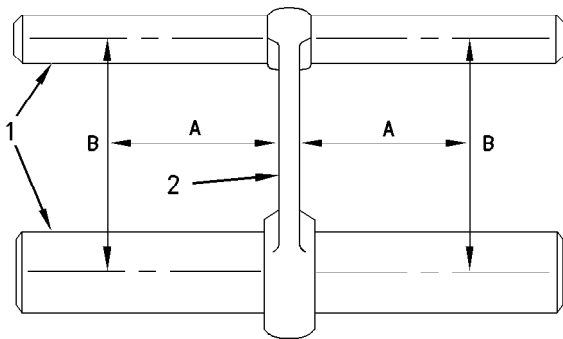

Illustration 83 g00690891

### Inspection of the connecting rod parallel alignment.

- (1) Measuring pins
- (2) Connecting rod
- (A) Measure the distance 100 mm (3.94 inch) from the connecting rod.
- (B) Measure the distance between the center of the bore for the piston pin bearing and the center of the connecting rod bearing bore.

1. Use the appropriate tools in order to measure the distances for the connecting rod (2).

- Appropriate gauges for measuring distance
- Measuring pins (1)

**Note:** The connecting rod bearings should be removed before taking the measurements.

2. Measure the connecting rod for distortion and parallel alignment between the bores.

The measurements must be taken at distance (A). Distance (A) has a value of 100 mm (3.94 inch) from both sides of the connecting rod.

Measure length (B).

The total difference in measurements of length (B) from each side should not vary more than  $\pm 0.08$  mm ( $\pm 0.0031$  inch).

3. Inspect the piston pin bearing and the piston pin for wear and other damage.

4. Measure the clearance of the piston pin in the piston pin bearing. Refer to Specifications, "Connecting Rod" for clearance dimensions.

i01748770

## Connecting Rod Bearings - Inspect

Check the connecting rod bearings and the connecting rod bearing journal for wear or other damage.

Connecting rod bearings are available with a smaller inside diameter than the original size bearings. These bearings are for crankshafts that have been ground.

i01748792

## Main Bearings - Inspect

Check the main bearings for wear or other damage. Replace both halves of the bearings and check the condition of the other bearings if a main bearing is worn or damaged.

Main bearings are available with a smaller inside diameter than the original size bearings. These bearings are for main bearing journals that have been ground.

i02193978

i06943718

## Cylinder Block - Inspect

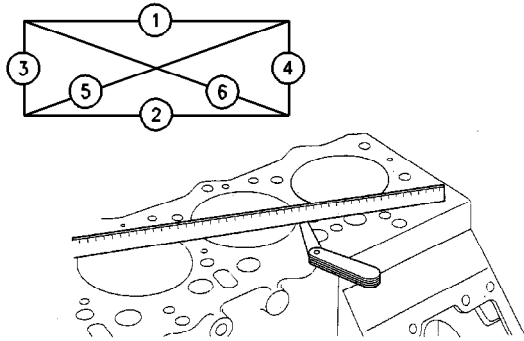

Illustration 84

g00907375

Use a straight edge and a feeler gauge to check the six positions for flatness. Refer to Illustration 84 .

Inspect the top of the cylinder block for cracks, damage, and warpage.

Inspect each cylinder bore. There should be no scoring, rust or corrosion. Use a suitable gauge in order to measure each cylinder bore. Measure the area of each cylinder bore that is in contact with the top, middle and bottom piston rings. Each cylinder bore should be measured at 90 degrees to the crankshaft.

### NOTICE

The flex-hone process must not be used on these engines.

If the cylinder bores exceed the service limit, the cylinder block must be renewed. Refer to Specifications, "Cylinder Block" for the bore diameters and tolerances.

## Cylinder Head - Inspect

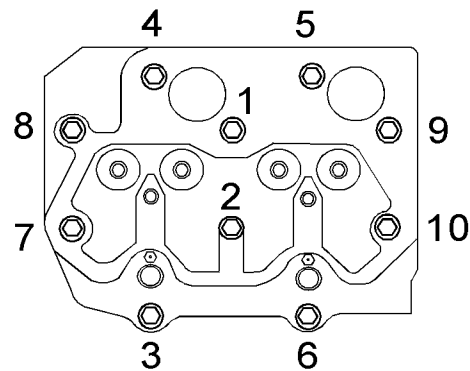

Illustration 85

g01317344

Bolt tightening sequence for two cylinder engines

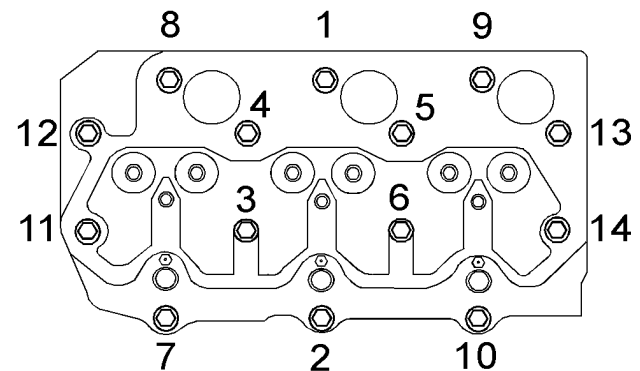

Illustration 86

g01317351

Bolt tightening sequence for three cylinder engines

1. Remove the bolts in the cylinder head in the reverse sequence that is shown in Illustrations 85 , and 86 .

Remove the cylinder head from the engine.

2. Clean the cylinder head thoroughly. Ensure that the contact surface of the cylinder head and the contact surface of the cylinder block are clean, smooth, and flat.
3. Inspect the bottom surface of the cylinder head for pitting, corrosion, and cracks. Inspect the area around the valve seats and the holes for the fuel injectors.

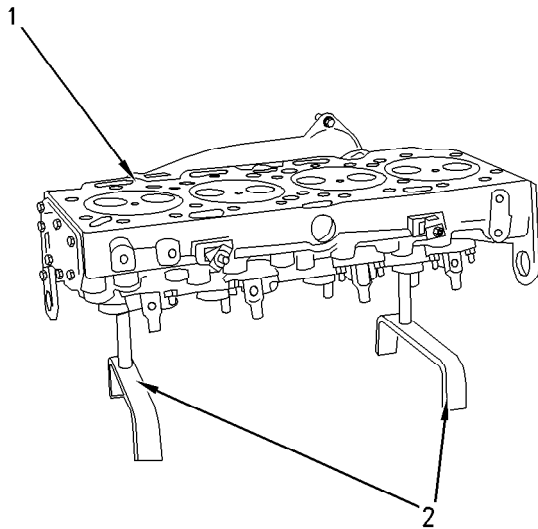

Illustration 87 g00842292  
Typical example

4. Put the cylinder head (1) on suitable supports (2).

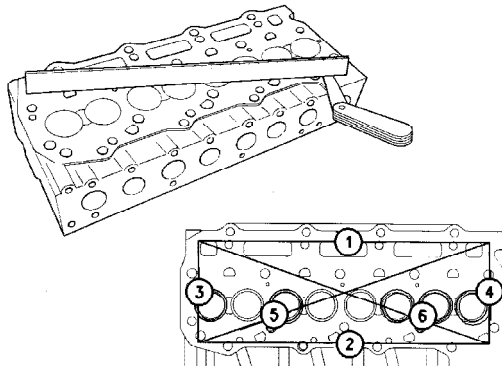

Illustration 88 g00907448  
Typical example

5. Use a straight edge and a feeler gauge to check the six positions of the cylinder head for distortion. Refer to Specifications, "Cylinder Head" for the requirements of flatness.

i02194219

## Piston Height - Inspect

Table 9

Required Tools		
Part Number	Part Description	Qty
21825617	Dial gauge	1
21825496	Dial gauge holder	1

If the height of the piston above the cylinder block is not within the tolerance that is given in the Specifications Module, "Piston and Rings", the bearing for the piston pin must be checked. Refer to Testing and Adjusting, "Connecting Rod - Inspect". If any of the following components are replaced or remachined, the piston height above the cylinder block must be measured:

- Crankshaft
- Cylinder head
- Connecting rod
- Bearing for the piston pin

The correct piston height must be maintained in order to ensure that the engine conforms to the standards for emissions.

**Note:** The top of the piston must not be machined. If the original piston is installed, be sure that the original piston is assembled to the correct connecting rod and installed in the original cylinder.

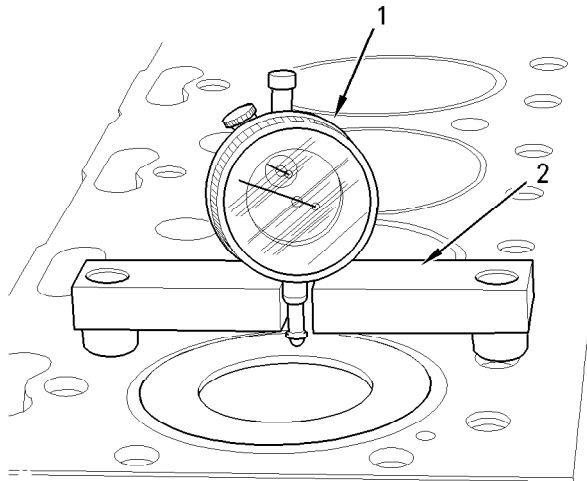

Illustration 89

g00953648

- (1) Dial gauge  
(2) Dial gauge holder

1. Use the dial gauge (1) and the dial gauge holder (2) in order to measure the piston height above the cylinder block. Use the cylinder block face to zero the dial gauge (1).
2. Rotate the crankshaft until the piston is at the approximate top center.

3. Position the dial gauge holder (2) and the dial gauge (1) in order to measure the piston height above the cylinder block. Slowly rotate the crankshaft in order to determine when the piston is at the highest position. Record this dimension. Compare this dimension with the dimensions that are given in Specifications, "Cylinder Head".

i02194222

## Flywheel - Inspect

### Alignment of the Flywheel Face

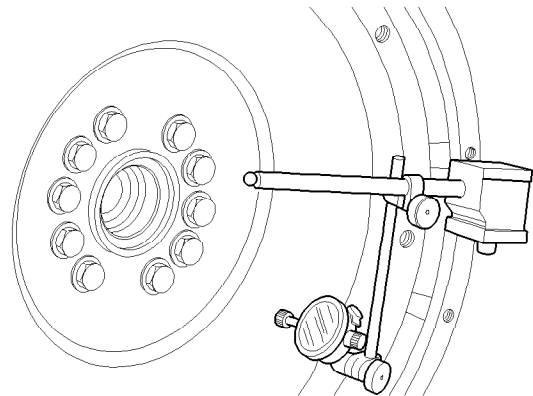

Illustration 90

g00987751

1. Install the dial indicator. Refer to Illustration 90 .
2. Set the pointer of the dial indicator to 0 mm (0 inch).
3. Turn the flywheel. Read the dial indicator for every 90 degrees.

**Note:** During the check, keep the crankshaft pressed toward the front of the engine in order to remove any end clearance.

4. Calculate the difference between the lowest measurement and the highest measurement of the four locations. This difference must not be greater than 0.03 mm (0.001 inch) for every 25 mm (1.0 inch) of the radius of the flywheel. The radius of the flywheel is measured from the axis of the crankshaft to the contact point of the dial indicator.

## Flywheel Runout

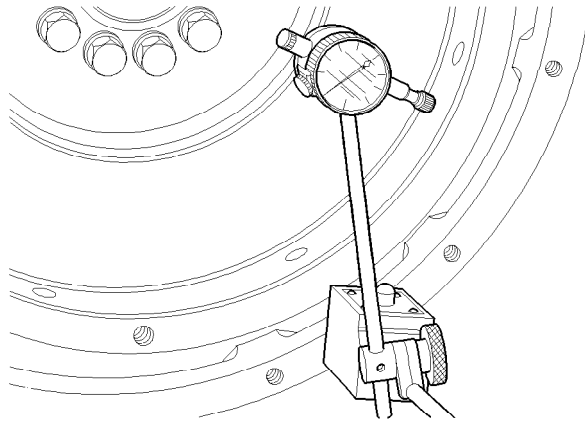

Illustration 91 g00987752

1. Install the dial indicator. Refer to Illustration 91 .
2. Set the pointer of the dial indicator to 0 mm (0 inch).
3. Turn the flywheel. Read the dial indicator for every 90 degrees.
4. Calculate the difference between the lowest measurement and the highest measurement of the four locations. This difference must not be greater than 0.20 mm (0.008 inch).

i05191413

## Flywheel Housing - Inspect

Table 10

Required Tools		
Part Number	Part Name	Qty
21825617	Dial Indicator Group	1

## Face Runout (Axial Eccentricity) of the Flywheel Housing

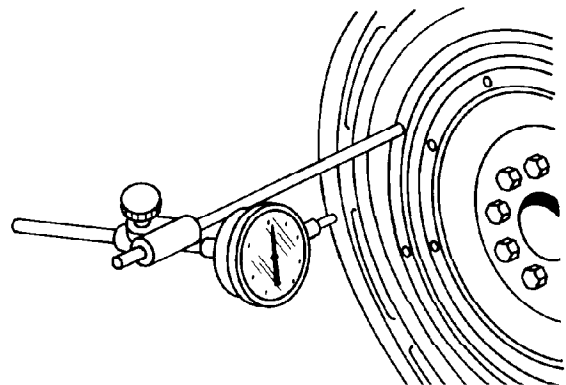

Illustration 92 g00285931

### 21825617 Dial Indicator Group

1. Fasten a dial indicator to the flywheel so the anvil of the dial indicator will contact the face of the flywheel housing.
2. Put a force on the crankshaft toward the rear before the dial indicator is read at each point.

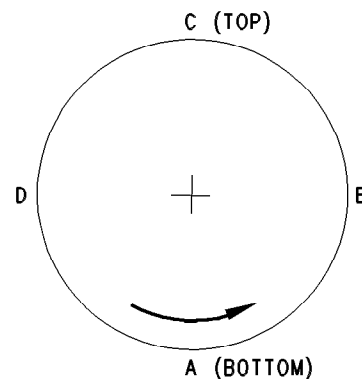

Illustration 93 g00285932

### Checking face runout of the flywheel housing

3. Turn the flywheel while the dial indicator is set at 0.0 mm (0.00 inch) at location (A). Read the dial indicator at locations (B), (C), and (D).

4. The difference between the lower measurements and the higher measurements that are performed at all four points must not be more than 0.20 mm (0.008 inch) for an "SAE 5" flywheel housing. The difference between the lower measurements and the higher measurements that are performed at all four points must not be more than 0.23 mm (0.009 inch) for an "SAE 4" flywheel housing. These measurements are the maximum permissible face runout (axial eccentricity) of the flywheel housings.

3. The difference between the lower measurements and the higher measurements that are performed at all four points must not be more than 0.20 mm (0.008 inch) for an "SAE 5" flywheel housing. The difference between the lower measurements and the higher measurements that are performed at all four points must not be more than 0.23 mm (0.009 inch) for an "SAE 4" flywheel housing. These measurements are the maximum permissible bore runout (radial eccentricity) of the flywheel housings.

## Bore Runout (Radial Eccentricity) of the Flywheel Housing

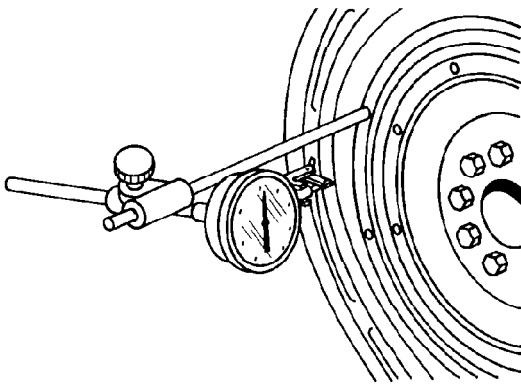

Illustration 94 g00285934  
21825617 Dial Indicator Group

1. Fasten a dial indicator to the flywheel so the anvil of the dial indicator will contact the bore of the flywheel housing.

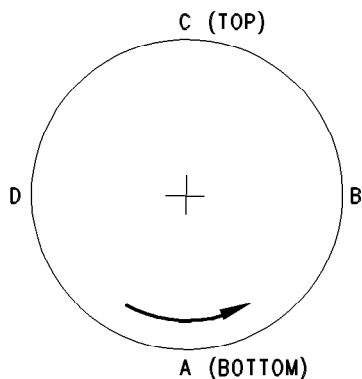

Illustration 95 g00285932  
Checking bore runout of the flywheel housing

2. Turn the flywheel while the dial indicator is set at 0.0 mm (0.00 inch) at location (A). Read the dial indicator at locations (B), (C), and (D).

i02617095

## Gear Group - Inspect

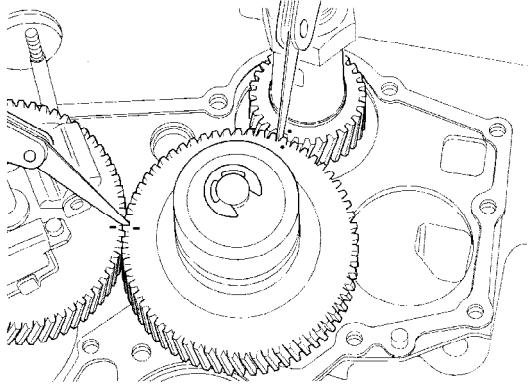

Illustration 96

g00907566

1. Inspect the gears for wear or damage. If one or more of the gears are worn or damaged, use new parts for replacement.
2. Measure the backlash of the gears with a feeler gauge. Refer to Illustration 96 . If the backlash measurement is greater than the maximum, install new gears.

**Note:** Refer to Specifications, "Gear Group (Front)" for the minimum and maximum backlash measurements.

# Electrical System

i02195377

## Alternator - Test

1. Put the positive lead "+" of a suitable multimeter on the "Bat" terminal of the alternator. Put the negative "-" lead on the ground terminal or on the frame of the alternator. Put a suitable ammeter around the positive output wire of the alternator.
2. Turn off all electrical accessories. Turn off the fuel to the engine. Operate the starter motor for 30 seconds. Wait for two minutes in order to cool the starter motor. If the electrical system appears to operate correctly, operate the starter motor again for 30 seconds.

**Note:** Operating the starter motor for 30 seconds partially discharges the batteries in order to do a charging test. If the battery has a low charge, do not perform this step. Jump start the engine or charge the battery before the engine is started.

3. Start the engine and run the engine at high idle.
4. Check the output current of the alternator. The initial charging current should be equal to the minimum full load current or greater than the minimum full load current. Refer to Specifications, "Alternator and Regulator" for the correct minimum full load current.

Table 11

Fault Conditions And Possible Causes			
Current At Start-up	The Voltage Is Below Specifications After 10 Minutes.	The Voltage Is Within Specifications After 10 Minutes.	The Voltage Is Above Specifications After 10 Minutes.
Less than the specifications	Replace the alternator. Check the circuit of the ignition switch.	Turn on all accessories. If the voltage decreases below the specifications, replace the alternator.	-
Decreases after matching specifications	Replace the alternator.	The alternator and the battery match the specifications. Turn on all accessories in order to verify that the voltage stays within specifications.	Replace the alternator.
The voltage consistently exceeds specifications.	Test the battery. Test the alternator again.	The alternator operates within the specifications. Test the battery.	Replace the alternator. Inspect the battery for damage.

5. After approximately ten minutes of operating the engine at high idle, the output voltage of the alternator should be  $14.0 \pm 0.5$  volts. Refer to the Fault Conditions And Possible Causes in Table 11

6. After ten minutes of engine operation, the charging current should decrease to approximately 10 amperes. The actual length of time for the decrease to 10 amperes depends on the following conditions:

- The battery charge
- The ambient temperature
- The rpm of the engine

Refer to the Fault Conditions And Possible Causes in Table 11 .

i01899136

## Battery - Test

Most of the tests of the electrical system can be done on the engine. The wiring insulation must be in good condition. The wire and cable connections must be clean, and both components must be tight.

### WARNING

**Never disconnect any charging unit circuit or battery circuit cable from the battery when the charging unit is operated. A spark can cause an explosion from the flammable vapor mixture of hydrogen and oxygen that is released from the electrolyte through the battery outlets. Injury to personnel can be the result.**

The battery circuit is an electrical load on the charging unit. The load is variable because of the condition of the charge in the battery.

### NOTICE

The charging unit will be damaged if the connections between the battery and the charging unit are broken while the battery is being charged. Damage occurs because the load from the battery is lost and because there is an increase in charging voltage. High voltage will damage the charging unit, the regulator, and other electrical components.

The correct procedures to test the battery can be found in the manual that is supplied by the OEM.

i02196181

## Charging System - Test

The condition of charge in the battery at each regular inspection will show if the charging system is operating correctly. A repair is necessary when the battery is constantly in a low condition of charge or a large amount of water is needed. There are no adjustments on maintenance free batteries. A large amount of water would be more than one ounce of water per cell per week or per every 100 service hours.

Whenever it is possible, test the charging unit and the voltage regulator on the engine. This test will use wiring and components that are a permanent part of the system. Off-engine testing or bench testing will give a test of the charging unit and voltage regulator operation. This testing will give an indication of needed repair. After repairs are made, perform a test in order to prove that the units have been repaired to the original condition of operation.

## Alternator Regulator

The charging rate of the alternator should be checked when an alternator is charging the battery too much or not charging the battery enough.

Alternator output should be  $14 \pm 0.5$  volt. No adjustment can be made in order to change the rate of charge on the alternator regulator. If the rate of charge is not correct, a replacement of the regulator is necessary. For individual alternator output, refer to Specification, "Alternator and Regulator".

i06753427

## Coolant Temperature Switch - Test (Coolant Temperature Sensor)

This procedure tests the coolant temperature switch for correct operation. Perform this procedure when the engine is running.

1. Use a suitable digital multimeter to measure the resistance of the coolant temperature sensor. When the temperature of the coolant is  $30^{\circ}\text{C}$  ( $86^{\circ}\text{F}$ ) or less, disconnect the wire connector from the coolant temperature sensor.
2. Place one lead of the multimeter on the connector of the coolant temperature sensor. Place the other lead of the multimeter on a ground for the coolant temperature sensor.  
  
Measure the resistance. The resistance should be approximately 1660 Ohms.
3. Repeat the previous step when the temperature of the coolant is approximately  $70^{\circ}\text{C}$  ( $158^{\circ}\text{F}$ ). The resistance should be approximately 428 Ohms.

- If the resistance through the coolant temperature sensor is not within the given resistances, replace the coolant temperature sensor.

i02196199

## Electric Starting System - Test

Use a suitable multimeter in the "DC volts" range to find starting system components which do not function.

Move the start control switch in order to activate the starter solenoid. The operation of the starter solenoid can be heard as the pinion of the starter motor is engaged with the ring gear on the engine flywheel.

If the solenoid for the starter motor will not operate, it is possible that the current from the battery did not reach the solenoid. Fasten one lead of the multimeter to the connection (terminal for the battery cable on the solenoid). Connect the other lead to a good ground. A zero reading indicates that there is a broken circuit from the battery. More testing is necessary when there is a voltage reading on the multimeter.

The operation of the solenoid also closes the electric circuit to the starter motor. Connect one lead of the multimeter to the solenoid connection (terminal that is fastened to the starter motor). Connect the other lead to a good ground. Activate the starter solenoid and look at the multimeter. A voltage reading of the battery shows that the problem is in the starter motor. The starter motor must be removed for further testing. A zero reading on the multimeter shows that the solenoid contacts do not close. This indicates the need for repair to the solenoid, or to the clearance for the starter motor pinion.

Perform a test. Fasten one multimeter lead to the connection (terminal for the small wire at the solenoid and fasten the other lead to the ground. Look at the multimeter and activate the starting solenoid. A voltage reading shows that the problem is in the solenoid. A zero reading indicates that the problem is in the start switch or the wires for the start switch.

Fasten one multimeter lead to the start switch at the connection (terminal for the wire from the battery). Fasten the other lead to a good ground. A zero reading indicates a broken circuit from the battery. Check of the circuit breaker and wiring. If there is a voltage reading, the problem is in the start switch or in the wires for the start switch.

A starter motor that operates too slowly can have an overload due to excessive friction in the engine that is being started. Slow operation of the starter motor can also be caused by a short circuit, loose connections, and/or dirt in the starter motor.

i06508434

## Engine Oil Pressure Switch - Test

This procedure tests the engine oil pressure switch for correct operation.

- Turn the ignition switch to the ON position, but do not start the engine. The oil pressure lamp should turn on for 0.5 seconds. This checks the lamp to determine if the lamp is operating correctly.
- If the lamp does not turn on for 0.5 seconds, check the electrical circuit to the lamp for a short or an open circuit. Check the engine oil pressure switch for a short or an open circuit. Check the bulb for the lamp for damage.
- If the circuit is correct, replace the engine oil pressure switch. If the circuit is repaired or if the engine oil pressure switch or lamp are replaced, repeat this step to ensure that the lamp turns on for 0.5 seconds.
- Remove the engine oil pressure switch from the cylinder block. Disconnect the wire connector on the wiring harness from the engine oil pressure switch. Use a 12 V battery as a power source. Connect the terminals of the battery, the engine oil pressure switch, and the leads of a suitable digital multimeter in series. Measure the current through the engine oil pressure switch.
- The current should be 0.30 to 0.40 A. If the current through the engine oil pressure switch is greater than 0.42 A, replace the engine oil pressure switch.

i02196363

## Fuel Shutoff Solenoid - Test

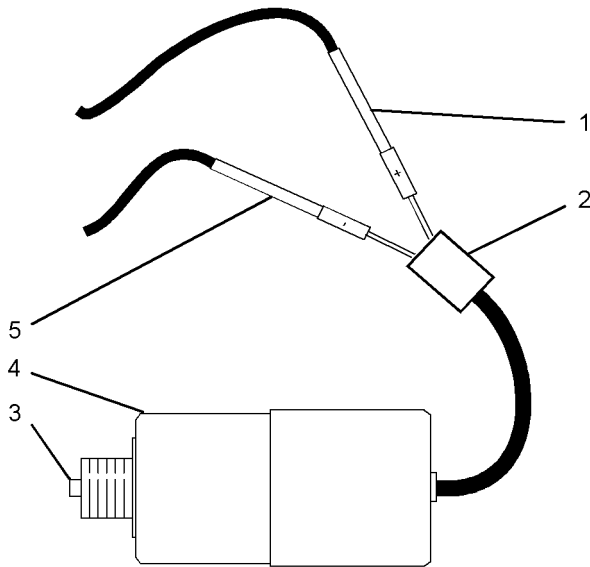

Illustration 97

g01115662

- (1) Positive "+" lead
- (2) Electrical connector
- (3) Plunger
- (4) Body of the fuel shutoff solenoid
- (5) Negative "-" lead

This procedure tests the fuel shutoff solenoid for correct operation.

1. Remove the fuel shutoff solenoid from the engine. Refer to Disassembly and Assembly, "Fuel Shutoff Solenoid - Remove and Install".
2. Use a 12 volt battery as a power source. Connect the lead from the battery positive terminal (1) to one of the pins in the electrical connector (2) on the fuel shutoff solenoid. Connect the lead from the battery negative terminal (5) to the remaining pin in the electrical connector (2) on the fuel shutoff solenoid.

The plunger (3) on the fuel shutoff solenoid (4) will extend the maximum distance when the leads are connected.

If the plunger does not move or if the plunger does not extend the maximum distance, replace the fuel shutoff solenoid.

3. Use a suitable digital multimeter to measure the current through the fuel shutoff solenoid. Connect the battery, the fuel shutoff solenoid, and the leads of the multimeter in series.

The current should be  $1.0 \pm 0.1$  amperes. If the current is not within this tolerance, replace the fuel shutoff solenoid.

4. Install the fuel shutoff solenoid on the engine. Refer to Disassembly and Assembly, "Fuel Shutoff Solenoid - Remove and Install".

i08142897

## Glow Plugs - Test

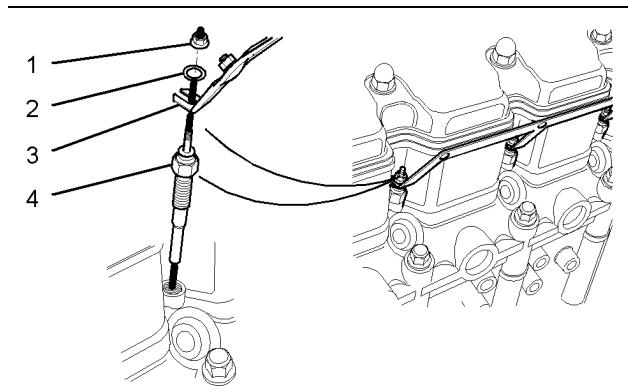

Illustration 98

g01109557

### Typical example

- (1) Nut
- (2) Washer
- (3) Connector
- (4) Glow plug

## Continuity Test

1. Connect a suitable test light between a ground and the terminal of the glow plug (4). Choose the glow plug that is farthest away from the battery. Turn the starting aid switch to the ON position.

If the circuit is correct, the test light should turn on.

If the test light does not turn on, inspect the circuit for loose connections, broken wires, and other damage.

2. Loosen the nut (1) on each glow plug and then disconnect the connectors (3) from the glow plugs (4).
3. Use a suitable digital multimeter to measure the resistance between the electrical terminal of the glow plug (4) and ground. The point for the ground should be as close to the glow plug as possible.

Maximum resistance for the glow plugs.

402J-05, and 403J-07 . . . . . 1.0 ohm

403J-11, 403J-11T, 403J-15, 403J-17, and 403J-17T . . . . . 0.0139 ohm

4. Connect the test light to the positive terminal of the battery and to the electrical terminal of the glow plug (4). If the light turns on, the continuity in the glow plug is correct.

If the light does not turn on, replace the glow plug.

Repeat this step for each glow plug.

5. Install the connector (3) on each glow plug (4) and tighten the nut (1).

## Glow Plug Circuit

1. Disconnect the power supply cable from the connector (3). Loosen the nut (1) and remove the connector (3) from the electrical terminal of the glow plug (4).
2. Connect the leads of a suitable ammeter between the power supply cable and the terminal of a glow plug and then connect the leads of the digital multimeter between the terminal of the glow plug and a ground. Turn on the starting aid switch. Observe the amperage reading of the ammeter and the voltage reading on the multimeter.

402J-05, and 403J-07

Maximum current through the glow plug . . . . . 11 amperes

Current through the glow plug after 6 seconds . . . . . 8.5 amperes

403J-11, 403J-11T, 403J-15, 403J-17, and 403J-17T

Maximum current through the glow plug . . . . . 11 amperes

Current through the glow plug after 6 seconds . . . . . 11.5 ± 1.5 amperes

The voltage should not drop more than 0.5 volts.

Perform step 2 for each glow plug.

3. If the multimeter reading is below the specified amperes, the glow plug should be replaced. If there is no reading, replace the glow plug.  
  
If the voltage reading of the multimeter is zero, inspect the starting aid switch and the power supply for faulty components and loose connections.
4. When the tests are complete, install the connector (3) to the terminal of each of the glow plugs (4) and tighten the nut (1). Connect the cable for the power supply to the glow plugs.



# Index

## A

Air in Fuel - Test .....	36
Air Inlet and Exhaust System .....	20, 55
Crankcase Breather .....	22
Cylinder Head And Valves .....	21
Turbocharger .....	21
Air Inlet and Exhaust System - Inspect .....	55
Alternator - Test .....	79

## B

Basic Engine .....	24, 71
Cylinder Head and Block .....	24
Pistons and Connecting Rods .....	24
Timing Gear Case and Gears .....	25
Battery - Test .....	80

## C

Charging System - Test .....	80
Alternator Regulator .....	80
Compression - Test .....	57
Compression .....	57
Connecting Rod - Inspect .....	71
Connecting Rod Bearings - Inspect .....	72
Coolant Temperature Switch - Test (Coolant Temperature Sensor) .....	80
Cooling System .....	23, 65
Cooling System - Check (Overheating) .....	65
Cooling System - Inspect .....	66
Cooling System - Test .....	66
Checking the Filler Cap .....	67
Testing The Radiator And Cooling System For Leaks .....	68
Cylinder Block - Inspect .....	73
Cylinder Head - Inspect .....	73

## E

Electric Starting System - Test .....	81
Electrical System .....	26, 79
Automatic Shutdown System .....	28
Charging System Components .....	33
Engine Electrical System .....	26
Other Components .....	35
Starting System Components .....	34
Engine Oil Pressure - Test .....	62
Engine Oil Pressure Switch - Test .....	81
Engine Oil Pump - Inspect .....	62
Engine Valve Lash - Inspect/Adjust .....	58
Valve Lash Adjustment .....	58
Valve Lash Setting .....	58
Excessive Bearing Wear - Inspect .....	63
Inspection Procedure .....	64
Introduction .....	63
Excessive Engine Oil Consumption - Inspect .....	64
Engine Oil Leaks into the Combustion Area of the Cylinders .....	64
Engine Oil Leaks on the Outside of the Engine ...	64
Introduction .....	64

## F

Finding Top Center Position for No. 1 Piston .....	37
Flywheel - Inspect .....	75
Alignment of the Flywheel Face .....	75
Flywheel Runout .....	76
Flywheel Housing - Inspect .....	76
Bore Runout (Radial Eccentricity) of the Flywheel Housing .....	77
Face Runout (Axial Eccentricity) of the Flywheel Housing .....	76
Fuel Injection Timing - Check .....	37
Fuel Injector - Test .....	38
Inspection and Cleaning of the Fuel Injectors .....	38
Leakage Test .....	39
Pressure Test .....	39
Test for the Nozzle Spray Pattern .....	40
Fuel Quality - Test .....	41
Fuel Shutoff Solenoid - Test .....	82
Fuel System .....	15, 36
Boost Compensation Device for Turbocharged Engines (if equipped) .....	18
Fuel Injection Pump .....	19
Fuel Injectors .....	19
Fuel Priming Pump .....	20
General Operation of the Fuel System .....	15
Glow Plugs .....	20
Governor .....	17
Fuel System - Inspect .....	36
Fuel System - Prime .....	42
Mechanical Fuel Priming Pump .....	42

## G

Gear Group - Inspect .....	78
Gear Group (Front) - Time .....	47
General Information .....	4
Engine Description .....	4
Engine Model Views .....	4
Glow Plugs - Test .....	83
Continuity Test .....	83
Glow Plug Circuit .....	83
Governor - Adjust .....	47
Final Installation of the New Front Housing .....	52
Record the Governor Settings .....	48
Removal of the Old Front Housing .....	49
Setting the Fuel Screw .....	52
Setting the New Front Housing .....	51

## I

Important Safety Information .....	2
------------------------------------	---

## L

Lubrication System .....	22, 62
--------------------------	--------

## M

Main Bearings - Inspect .....	72
-------------------------------	----

**P**

Piston Height - Inspect.....	74
Piston Ring Groove - Inspect.....	71
Inspect the Clearance of the Piston Ring .....	71
Inspect the Piston and the Piston Rings .....	71
Inspect the Piston Ring End Gap.....	71

**S**

Systems Operation Section.....	4
--------------------------------	---

**T**

Table of Contents .....	3
Testing and Adjusting Section .....	36

**V**

Valve Depth - Inspect.....	60
Valve Guide - Inspect.....	60

**W**

Wastegate - Test (Turbocharger - Inspect).....	55
Inspection of the Compressor and the Compressor Housing.....	56
Inspection of the Turbine Wheel and the Turbine Housing.....	56
Inspection of the Wastegate.....	57
Water Pump - Inspect.....	69
Water Temperature Regulator - Test .....	68
Introduction .....	68
References .....	68
Test Preparation .....	68
Test Procedure .....	68



M0087365  
©2022 Perkins Engines Company Limited  
All Rights Reserved